

Milford Conservation Commission

Milford, New Hampshire

Trails Manual

Developed by the
Conservation Land Management Committee



MILFORD CONSERVATION COMMISSION
TRAILS MANUAL

Scope

This manual provides guidelines and standards for the development and management of trails on properties that are owned by the Town of Milford, New Hampshire and are under the management of the Milford Conservation Commission.

Authoring Group

This manual was created by the Conservation Land Management Committee reporting to the Milford Conservation Commission.

Document Control

This document plus appendices are edited (based upon input from the Conservation Land Management Committee), issued, and distributed by the Milford Conservation Office.

Date of original issue: 01 May 2008
Date of this revision: 10 March 2011

TABLE OF CONTENTS

- Section I: Goals & Objectives [resolution]
- Section II: Definitions
- Section III: Standards for Trails
[Trail Route, Location, Width & Height; Signage; Parking]
- Section IV: Trail Laying Out, Building, Maintenance
[Principles for Laying Out a Sustainable Trail; Laying Out the Route for a New Trail; Maintenance - Hand Tools, Power Tools, Vegetation, Water]
- Section V: Standards for Site Improvements
[Kiosks, Information Boards, Signs, Blazes, Markers, Standard Hardware, Survey Tape, Pressure Treated Lumber, Bridges, Poison Ivy Control]
- Section VI: Volunteers
[Safety, Management of Adult Volunteers, Management of Youth Volunteers, Management of Trail Stewards]
- Section VII: Properties Managed by the CLMC, Responsibilities of CLMC Members for Specific Town Forests or Trail Systems
- Section VIII: Maps
- Section IX: Storage Shed
-
- Appendix A: References/Sources [Books, Manuals, Web Sites, Organizations, Grade / Slope Angle Conversion Table] Here are up-dates concerning the Souhegan River Trail from last evening's CLMC meeting.
- Appendix B: Guidance for Trails Stewards and Volunteers [Spring and Fall Trail Reports, Spring Trail Survey, Checklist for Backpack / Trail Supplies]
- Appendix C: Graphics
[Metal signs and markers, Documents for posting in all Kiosks, Brush Piles for Wildlife, Trail Work Permit]
- Appendix D: Construction Details
[Kiosks, Information Boards, Routed Signs and Posts, Small Bridges, Backing Plates for Metal Directional and Boundary Signs]
- Appendix E: Official MCC, Town of Milford, and State of NH Documents Pertaining to Trails
[Milford Trail Maps; Camping Permit, with Release & Waiver of Liability and Indemnity Agreement; State Law Regarding Posting of Signs; Town Regulation Regarding Conduct on Conservation Lands]

Section I: Goals & Objectives

Voted unanimously by the Milford Conservation Commission at their regular monthly meeting of 2007-06-14.

Resolution to Establish: “Conservation Lands Management Committee”

WHEREAS, the Milford Conservation Commission has the authority under RSA 36-A:4, “to acquire, maintain, improve, protect, or limit the future use of or otherwise conserve and properly utilize open spaces and other land and water areas within their town, and shall manage and control the same.” and

WHEREAS, the Milford Conservation Commission has been granted, under *Chapter 7.20 of the Municipal Code*, management of ‘conservation lands’ in Milford by the Milford Board of Selectmen, and

WHEREAS, the Milford Conservation Commission is committed to providing public use of conservation land which is compatible with the commission’s obligations regarding natural resource protection under *7.20.010: Declaration of Purpose: the Town of Milford has acquired rights to various tracts of land to be held for public use, such as hiking, skiing, nature study and other similar uses* and

WHEREAS, it has been determined by the commission that it is in the best interest of Town of Milford to institute a Management Committee, to work under the auspices of the commission, whose purpose is the management of public uses on conservation lands.

NOW THEREFORE BE IT RESOLVED, that the Milford Conservation Land Management Committee is hereby established to develop a comprehensive management plan, for all town lands and easements that provide for public use, to be approved by the Milford Conservation Commission and that said committee will act upon the plan to institute an ongoing stewardship program and that the following individuals shall be named as initial members of the CLM Committee:

Tim Barr	Brian Hawkins
Chris Costantino, MCC	Jon Thunberg
Diane Fitzpatrick, MCC	

[The name of the committee which is the subject of this Resolution is the (Milford) Conservation Land Management Committee (CLMC).]

Section II: Definitions

Acronyms and Symbols Used In This Document

CLMC	(Milford) Conservation Land Management Committee
IMBA	International Mountain Bicycling Association
MCC	Milford Conservation Commission
NEMBA	New England Mountain Bicycling Association
§	Symbol for Section

Definitions

Abney Level: A survey instrument used to measure grade.

Arc View: **The software used by the Town of Milford to develop GIS maps. The same software is used by the MCC office to produce trail maps.**

Berm: A mound of soil that runs parallel with a trail on the downslope side.

Cairn: A trail marker consisting of stones stacked one upon the other. Usually in rocky spots that are inappropriate for blazing or trail signs.

Clinometer, or, Inclinator: A hand-held device used to measure grade / slope.

Dip: A wide but shallow ditch generally cut at right angles to a trail to allow water to run off of the trail at low velocity with minimal erosion.



Directional Markers: A 4"x 4" aluminum sign used to indicate the direction of a trail. These signs are specific to trails on Milford conservation lands.

Fall Line: The steepest line that a trail could follow. The fall line cuts across contour lines at a 90° angle.

Geographic Information System (GIS): **A complex mapping system generally used by municipalities and major conservation organizations. The system has multiple layers - each layer maps a specific entity; e.g. , tax maps with boundary lines, water lines, wet lands, trails, etc.**

Grade Reversal: See "Dip"

Grade / Slope: A measurement of the rate of rise of a trail expressed as a percentage. A trail that rises 9 vertical feet in 100 horizontal feet has a 9% grade.

Half Rule: The treadway should cross contour lines at no more than 45 deg.

Information Board: A wood structure used to display minimal but useful information at various locations along trails.

Kiosk: A structure, usually at a trailhead, that contains information about the trail or information related to hiking

McLeod: A heavy duty combination rake and hoe with a 12" steel blade. It is used for firefighting but is also used for a wide variety of trail work.

Outslope: The grade from the up-hill edge to the down-hill edge perpendicular to a trail. An outslope of 3% is recommended to allow for proper sheet drainage.

Pulaski: "A single-bit ax with a small grub-hoe blade designed for fighting fires. It can be used for sidehill grubbing, cutting roots, removing blowdowns, cleaning drainages, and

other trail maintenance.”

Route: The course over the landscape chosen for the location of a trail.

Single Track: A single track is one on which users must generally travel in single file.

Swale: A depression constructed across a slope, above and in conjunction with, an earthen Berm.

Switchback: A turn in the opposite direction which is used to gain elevation on a side-hill trail.

Trail: a zone that includes the treadway and the area above and to the sides of it, typically 4'x8', may be more or less depending on the needs of the users

Trail Corridor: The area on either side of a trail which impacts or enhances the environment of the trail as experienced by the user.

Trailhead: An entry or starting point for a trail

Trail Signs: Trail signs are wooden signs on the trail that indicate the trail's name, direction, and distance to a significant location point. They are typically located at the trailhead and trail intersections to keep the hiker oriented correctly.

Trail Steward: A volunteer who agrees to maintain a specific trail or section of a trail and to report to the CLMC on the condition of the assigned trail.

Treadway: The area of a trail that is worn by foot, bicycle, or other traffic.

Water bar: A rock, earthen, or log barrier angled across a trail to divert runoff water off of the trail.

Section III: Standards for Trails in the Town of Milford

The goal for establishing standards is to create an inviting, easy to use, sustainable trail system for the enjoyment of trail users. These standards will apply to all trail systems on properties under the auspices of the MCC. Only trails approved by the MCC or CLMC are allowed on these properties as specified by Town Ordinance No. 7.20.013: *Conduct on Conservation Lands*. [see Appendix E for a copy of this regulation]

The trails on Milford Conservation lands are for general use and should be accessible to the majority of the citizens wishing to use these trails. These trails are not intended to be challenging; however, there may be sections that are more difficult in order to provide access to desirable geographic features or to connect to existing trails.

Trail

Trail Route: A well designed route will help keep users on the trail

1. The anticipated trail user must be considered when laying out a new trail; e.g., walkers, mountain bikes, horses, snowmobiles, crosscountry skiing
2. Trails shall have a purpose; e.g., go to a destination, be a connection, supply distance for biking or running
3. Trails should have a destination; e.g., hill-top, stream, road, other trail system
4. Trails should pass thru or by interesting features; e.g., big trees, erratics, cliffs, streams
5. Trails should avoid dead-ends unless the end is a special destination

Trail Location

1. Trails should avoid wetlands and take the least invasive route around wetlands. Seasonal changes should be considered; e.g., the CLMC may elect to close some trails during wet periods.
2. The uphill and downhill grades of walking trails should be moderate to allow access for the average person to traverse safely. The maximum average grade of trail sections should be kept to about 10% (6°).
3. Side-hill trails are best. Flat terrain should be avoided whenever possible, since these are areas where water will tend to collect.
4. Trails should cut across contour lines at a maximum angle of about 45°.
5. Switch-backs should be used to minimize the effects of the overall grade. For use by bicycles, these should have a minimum radius of about 20'.
6. Mountain bike trails should be designed and constructed by experienced people and according to the guidelines in publications such as Trail Solutions and Managing Mountain Biking (see Appendix A).

Trail Width and Height

1. The minimum width of a trail is 4' and the minimum height is 8'. For visual reference, brush and limbs should be trimmed so that the trail width and height should allow a full sheet of plywood (4' x 8') to go down the trail.
2. The width of the treadway in the center of the trail may vary depending upon the terrain. The minimum width is about 2'.
3. Equestrian trails need 10' of height
4. In some areas where a 'wilderness' experience is desired or where the grade is significantly greater than 10%, the trail may be designed as a single track.

Signage – Good trail signage and blazing will also help keep users on the trail. [see § V and Appendix C-1

Parking

All properties should have parking to accommodate several cars located near at least one trailhead.

Trailhead parking areas should have a *Trail Head Parking* sign.

Section IV: Laying Out, Building, and Maintaining Trails

The CLMC will decide if development of a new trail, or relocation of an existing trail, is warranted.

A. Principles for Laying Out A Sustainable Trail

Most of the following recommendations are taken from Managing Mountain Biking - IMBA's Guide to Providing Great Riding; International Mountain Biking Association, Pete Webber, editor

“The principals for laying out a trail can be summarized as one goal: **Get water off the trail and keep users on it.**”

An ideal trail will simultaneously incorporate the following sustainable trail principles.

1. **Trail Location:** Sidehill trails are best, with an average grade of 10% (6°) or less. Flat terrain should be avoided whenever possible, since these are areas where water will tend to collect.
- 2 & 3. **Avoid the Fall line, and, Use the Half Rule to Guide Trail Alignment:** “Avoid the most direct route.” “The trail should always climb or descend gradually. A trail’s grade should never exceed half the grade of the sideslope it is located on.” Or stated another way; a trail’s grade should never cut across contour lines at an angle greater than 45°.
4. **Sustainable Grade: *The Ten Percent Average (or Overall Trail Grade) Guideline:*** “An average trail grade of 10% (6°) is a sustainable target.” There will always be sections of trails that are greater or less than this 10% average.
5. **Maximum Sustainable Trail Grades:** “The maximum sustainable trail grade is about 15% (8.5°) for a short distance, but it is site specific and fluctuates based upon several factors. It could be as low as 4% (2.3°) or as high as 25% (14°)”.

These guidelines for trail grades are from Best Management Practices for Erosion Control During Trail Maintenance and Construction (see Appendix A for the full reference)

<u>Trail Type</u>	<u>Grade</u>
Hiking	10 – 12% (6° – 7°) sustained, pitch grades that are considerably steeper are acceptable
Cross Country Skiing	8 – 17% (5° – 10°) sustained 20% (11°) maximum
Mountain Biking	4% (2°) sustained, 5% (3°) for long runs, grades of 10% (6°) can be considered

6. **Grade Reversals: Unbeatable Drainage:** “A grade reversal is a spot at which a trail briefly changes elevation, dropping subtly before rising again. This change in grade forces water to exit the trail at the low point of the grade reversal before it can gain more volume, momentum and erosive power.”
7. **Outslope: Ensuring Sheet Flow:** “As the trail crosses a hillside, the downhill or outer edge of the tread should tilt slightly down and away from the high side. This tilt is called outslope – it encourages water to sheet across and off the trail in a gentle, non-erosive manner instead of funneling down the trail’s center.”
8. **Adapt Trail Design to Soil Texture:** “A mix of different types of soil particles in which neither sand, clay, nor silt predominate, is ideal, because it drains well, holds together, and is easy to work with. The added presence of rock and gravel can improve a soil’s ability to withstand erosion and trail users. Uniform soils that are dominated by one particular type, such as sand, are most erosion prone. In these unstable soils, trail design plays an essential role in preventing erosion.”
9. **Minimize User-Caused Displacement:** “Abrupt turns and sharp hills are locations most susceptible to user-caused soil movement.” Some useful practices include:
 - a. Limit turns in a trail to a minimum radius of 20’.
 - b. Build-up insloped turns (also called bermed turns)
 - c. Harden the trail tread
10. **Prevent User-Created Trails:** “The intended trail must provide a better experience than traveling off-trail or on a user-created route. To achieve this, your trail should:
 - a. Go to appealing destinations
 - b. Have a stable and predictable surface
 - c. Stay well away from areas in need of protection
 - d. Provide a sought-after experience”
 - e. Good trail signage and blazing will also help to keep users on the trail.

B. Laying Out the Route for a New Trail

Specifying the route for a new trail is an iterative process. It is most efficient for a group of 2 or 3 people to first lay out the proposed new route. It is easiest to do this when the leaves are off the trees. Members of this team should wear bright vests so that they are more visible to each other.

This original route should be marked with a combination of survey tape and marking flags (small plastic flags mounted on stiff wires). Experience has shown that *Pink Glo* color is the most visible and is recommended for both the tape and the flags.

Sections of a few hundred yards should be done at a time. The initial route through each section should be first marked with marking flags since they can be pulled up and moved as the route is altered. Once the route seems appropriate, the flags can be pulled up and replaced with survey tape on trees. Marking flags should be left in places where the exact proposed route is not obvious, especially for swithbacks. Of course, the use of these flags is only possible when the ground is not frozen.

When the proposed route for the new trail is completed, it should be checked and changes made by a team of several people representing potential users of the trail. This will generally include members of the CLMC, persons with a particular interest in the new trail, plus a representative of the local mountain bicycle club.

Once the route has been defined, a team of volunteers can be assembled to build the new trail.

C. Maintenance: “All trails benefit from routine maintenance. The fundamental goal remains the same: get water off the trail and keep users on it.” (See references in Appendix A-1)

Hand Tools

1. Hand tools need to be appropriate for the job.
2. Tools must be in good condition.
3. Sharp tools are safer than dull tools.
4. CLMC has a limited supply of tools that may be borrowed or volunteers may use their own tools.
5. Tools useful in trail maintenance and construction include: tape measure, pry bar, loppers, pruning saw, bow saw, pole saw, shovels, pickaxe, rake, post hole digger, Pulaski, McLeod.

Power Equipment

There are no restrictions of use of power equipment other than chainsaws.

Power equipment that volunteers may occasionally use for trail building and maintenance are lawn mowers, leaf blowers and trimmers. Safety precautions include the wearing of ear and eye protection.

Chainsaws and Preparation for Cutting Operations

Primex, the town insurer, requires that anyone who uses a chainsaw on property owned or managed by the Town of Milford must have commercial liability coverage for themselves to do tree work. This effectively excludes Trail Volunteers from operating a chain saw on these properties.

The MCC may elect to have an insured contractor or the Department of Public Works do the chainsaw work.

The person operating the chainsaw will cut down pre-marked trees. Those trees that fall across a trail will be cut into lengths that can be handled by volunteers and he will also cut off the larger limbs that cannot be cut with loppers. Removal of brush and logs will be done later by volunteers.

Trees that fall away from the trail only need to be cut into lengths that allow sections to contact the ground.

Note: the following section is written with the assumption that a paid contractor will do the chainsaw work.

Cutting operations should be scheduled to make the most efficient use of the contractor's time; therefore, work in more than one town forest may be involved. Significant planning and preparation will be needed.

1. Volunteers should first walk the trails needing attention and mark the trees that require cutting with orange survey tape. Preferably, one should be the Trail Steward for that area and one should be a member of the CLMC. It is necessary to walk the trail in both directions; otherwise, many trees will be missed.
2. All trees that are within the 4' trail corridor should be marked. Dead or dying trees that are outside of the trail corridor that could fall across the trail should also be marked.
3. Trees outside of the trail corridor that are 4" or less in diameter at the base can be left for later cutting with hand tools.; therefore, it is not necessary to mark these trees.
4. An inventory of the trees to be cut, plus a general description of their location, should be prepared for the contractor so that he can better plan his work.
5. When the contractor arrives, it would be helpful if at least one of the persons who flagged the trees for cutting is present to lead the contractor to the work areas. If this is not feasible, the contractor should be provided with a map showing the location of the trees for cutting.
6. When the contractor has finished cutting, volunteers should be lined up for the following weekend for trail clearing.

Vegetation - Standards for Pruning or Cutting of Trees or Brush

1. Branches should be cut close to the trunk of the tree (not just back to the edge of the trail), and to a height of about 8'. [The latest recommendation for limbing a tree is to cut just beyond the initial swell of a branch as it leaves the trunk of a tree, this produces a smaller exposure for the tree to heal while still keeping the cut close to the trunk.]
2. Brush should be dragged off of the trail and put into small piles no closer than 10' from the trail. Where possible, the brush should be piled in a low spot where it will rot more quickly.
3. Branches and limbs should be laid parallel with the butt ends facing the same direction. This will minimize the size of the piles and accelerate their rate of decomposition.
4. Cut saplings close to the ground.
5. Dead stumps and tree limbs can become sharp "stickers" and are hazardous. Limbs should be removed with a saw or lopper rather than an axe.
6. Brush piles are excellent habitat for wildlife. See Appendix C-3 for information on location and construction of brush piles for this purpose.

Water - Drainage and Erosion Control

- a. The CLMC will be responsible for erosion control. Volunteers should not undertake erosion control actions except in coordination with the CLMC.
- b. See appendix A-1, reference [4] for erosion control information.
- c. Poor drainage is the primary cause of trail maintenance problems.

- d. Proper drainage will carry the water either across the trail, under the trail, or will intercept the water before it crosses the trail.
 - e. Cross drainage techniques, such as swales or water bars, should be installed to divert water off of the trail as soon as possible.
1. Swales/Dips/Berms

Conditions where appropriate:

- a. In areas where surface runoff might create erosion problems running across a trail.
- b. On slopes which have a trail grade less than 10% (6°).

Guidelines for Installing Swales and Berms

- a. Install swales at the top of any slope and at proper spacing along sloping sections of the trail.
- b. The swale can be as shallow or as deep as necessary, taking into consideration the expected trail use and the conditions.
- c. Soil should be removed from the swale and transferred to the downhill side to form the berm.
- d. The swale should be constructed at a 30°-45° angle down-slope from a line perpendicular to the direction of the trail.
- e. The downhill end of the swale should extend far enough to disperse the water flow away from the trail.
- f. The uphill end of the swale should extend far enough beyond the trail to fully intercept the flow of water.
- g. Alternative water drainage techniques, such as water bars, may be required if the swales are consistently becoming filled or breached.

2. Water Bars

Conditions where water bars are appropriate

The greater the slope and the higher the velocity or volume of water, the greater the need for water bars as opposed to other drainage techniques.

Guidelines for installing water bars

- a. Place each rock or log solidly into the ground, preferably using flat rocks or rot-resistant logs.
- b. Install water bars at the top of slopes and at the steep sections of the trail as needed.
- c. The water bar should be constructed at a 30-45° angle down-slope from a line perpendicular to the direction of the trail.
- d. Construct the water bar so that it extends at least 12" beyond both sides of the trail.
- e. At a minimum, the water bar should drain at a 3% out-slope.
- f. In a rock water bar, each rock should overlap the rock below it and be overlapped by the rock directly above it.
- g. A log water bar should be constructed with peeled logs at least 10" in diameter.
- h. Log water bars should be held in place with large stones.
- i. The channel created by the water outlet and the water bar itself can be lined with stones to reduce erosion.

Section V: Standards for Site Improvements

Kiosks

1. It is the goal of the CLMC to install and maintain at least one informational kiosk on each property we manage.
2. Kiosks will be located 10-30 yards from the entrance to the trail, but should be visible from the parking area or entrance to the trail.
3. Each kiosk will contain, at a minimum
 - a. Guidelines for trail use (allowed and prohibited uses)
 - b. Trail map
 - c. An explanation of the markers and blazes on the trail
 - d. The document, *Notice to Trail Users*
4. In addition to the minimal requirements kiosks may also display:
 - a. The Hike Safe Bulletin
 - b. Caution notice(s)
 - c. Pack-in–Pack-out requirement
 - d. Dog hiking etiquette
 - e. Animal/bird information
 - f. Features present on the property, stone foundations, waterfalls, etc.
 - g. Hiker participation suggestions for trail maintenance
5. Each kiosk should be inspected by a volunteer as part of the trail maintenance inspections. Problems and needed repairs should be noted on the trail report form.
6. Maintenance will be scheduled according to the reports submitted. The following should be anticipated regular maintenance activities at each kiosk:
 - a. Repairs (including lubrication of padlocks)
 - b. Signage
 - c. Update maps
 - d. Change faded maps
 - e. Add new information or re-formatted information
7. For construction details see appendix D-2 & 3.

Information Boards

The CLMC will use Information Boards along town trails to display maps or other useful information. Information Boards are small wood structures sized to display a single document (usually a trail map) at secondary trail heads or at various locations along trails, often at the junctions or two or more trails.

For construction details see appendix D-4.

Signs

a. Hiker



1. Hiker signs are used on public roads to indicate that a hiking trailhead is near-by. These signs can be located at the beginning of a trail or where the trail crosses a road.
2. Hiker Signs will be mounted on an 8' metal post sunk into the ground 3-4' deep.

3. Hiker Signs will be located on roads approximately 20' prior to the trailhead or the parking area for the trail-head.
4. Hiker Signs will be located on opposing sides of the trail-head to alert travelers from either direction.
5. When a sign's desired location would not be on town land or within the road right-of-way, permission to place a sign shall be received from the property owner.

b. Trail

1. Trail signs are typically routed wood boards that specify the name of a trail or trails
2. Trail signs will be located as determined by the CLMC.
3. Trail names on these signs will be identical to trail names on maps. Abbreviations should be avoided unless dictated by maps.
4. Trail signs will clearly designate the name and direction of the intersecting trails.
5. Trail signs may also provide the distance to a significant location point along that trail.
6. For construction and installation details see Appendix D-5.

c. Blazes

1. Blazes should be applied 5' - 6' above the base of a live tree. Blazes can also be painted on rocks. They should be used with discretion. Where the location of the trail is obvious, few blazes should be used. Where the location of the trail might not be obvious to the inexperienced hiker, blazes should be placed so that from each blaze, the next one is visible. A good way to decide where blazes will be needed is to visualize what the trail would look like with one foot of snow on it. Blazes must be applied in both directions. It is best to paint blazes while walking in one direction, and then to do the same in the reverse direction.
2. When old blazes have to be removed they should be obliterated as much as possible with a paint scraper or wire brush. If this does not totally remove the blaze, it should be painted over with gray or brown oil-based flat (usually primer) paint.
3. The blazes should be 2.5" wide by 6" tall. They should be painted neatly with sharp edges; a 1" brush is recommended. After the first coat is cured, a second coat should be applied.
4. Surface preparation is necessary before painting. A wire brush can be used to clean surfaces of rocks or the smooth bark of some trees. If the bark is rough/ thick, a paint scraper should be used. Scrape an area on the bark that is larger than the actual blaze size. Scrape off the rough bark until you get a relatively smooth surface. If you notice drip areas and irregular shaped blazes after you have painted, the blaze can be shaped by scraping off the drip areas and shaping the sides of the blaze.
5. Colors and Paint for Blazes: A specific paint in three different colors has been adopted by the CLMC for blazes for specific types of trails.

Paint	Benjamin Moore High Gloss or Semi Gloss Alkyd (Oil) Metal & Wood Enamel
White	<i>White</i> (#13301): The color used for the main trail, including the connecting trail to the primary parking area for that trail.

Blue *Blue Wave* (#2065-50): The color used for side trails that loop back onto the main trail.

Yellow *Yellow Flash* (#2021-10): Trails that lead off of the main trail to an alternative trailhead.

6. Suggested techniques: Always carry a small pruning saw since branches may need to be removed before a blaze is applied / Transfer the paint to a small plastic container with a screw top (Parmesan cheese jars or small peanut butter jars work well) / Keep the wet paint brush in a plastic bag / /Carry supplies in a 5 gallon plastic bucket: These supplies should include paint, paint brush, paint scraper, wire brush, and a pruning saw; additional useful items include surgical-type gloves, directional markers, nails, hammer, clippers.

d. Directional Markers

Directional markers are 4" aluminum squares with an arrow in the center and the words *Milford Public Hiking Trail* printed around the outside. They are white, blue, or yellow.



Left Turn



Straight Ahead



Right Turn

- The markers should be used at the start of the trail and at every point where there is a sharp turn in the direction of the trail. On occasion, two markers may be needed at the same point. Additional markers can be added if necessary to ensure clear trail identification.
- Color coding is the same as for trail blazes.
- Markers should be placed 5'-6' above the base of a live tree.
- The markers should be loosely attached to live trees with Hy-tensil alloy aluminum nails, 1 3/4" Ring Grip Roofing Nails. The gap between the marker and the tree should be about 1/4-1/2" to allow for tree growth.
- If a marker is needed where there is no suitable tree, a post and sign mounted on a backing plate can be used. See Appendix D-7 for construction details.



e. Boundary Markers and Blazes

Boundary Markers will be displayed to indicate the boundary of town conservation land or to inform hikers where a trail that is not supported by the CLMC leaves Milford conservation land. The *Boundary Marker* sign should be placed on a tree facing the adjacent property. A *Stop – Leaving the Public Trail* sign should be placed on a tree facing the trail.

About every 10 years, the Town of Milford hires a forester to update the management plans of the town forests. If needed, the blazes on the boundary line are refreshed or blazed with an axe and fresh blazes are painted with red paint. CLMC or MCC members may open up the scars on boundary line trees and repaint them so long as there is evidence of a blaze that

was done by a surveyor. New scars must not be opened – only licensed surveyors can do this. Paint specially formulated for this purpose is stored in the MCC shed. The recommended paint is *Aervoe* red Tree Marking Paint. This is available from Benmeadows.com.

The standard scar blazes used by surveyors are:

- On a tree which is exactly on the boundary line: two slashes, one each on opposite sides of the tree.
- On a tree which is to the left or to the right of the boundary line: one slash on the side facing the line.
- Boundary corners are marked by three “witness” or “bearing” trees. Each of the three trees is marked with three slashes facing the corner monument or pin.

It is sometimes necessary for the MCC or CLMC to locate boundary markers or to locate and mark boundary lines. Surveyors mark boundary points with pins, granite markers, stones, or drill-holes in stones. Boundary lines are often marked with orange survey tape on boundary trees. Once these are located, it is very helpful to mark or refresh these points or lines so that they can be more easily located in the future.

- Pins and drill-holes should be painted with orange paint.
- Pins or corner-stones can be further marked with the MCC Boundary Marker signs mounted on a wooden back-plate and attached to a metal post.
- The orange tape on boundary lines should be periodically replaced with new tape.

f. Other Markers

Cairns: Tapered piles of stones at least 18” high can be used in areas where there are few or no trees.

Symbols on Posts: As an alternative to cairns and where the terrain is not rocky, a post with the diamond directional marker or a board painted with a blaze can be used. Posts can be metal or pressure-treated 4 x 4s.

Cultivated Land – Trail Boundary Posts: Some sections of trails are at the edges of fields tilled by farmers. With the permission of the farmer/landowner, tall posts can be installed to provide demarcation between the tilled land and the trail to prevent annual disruption of the trail. Construction and mounting of such markers is described in Appendix D-6.

g. Other Signs

Several standard printed aluminum signs are available for specific uses. These are shown in Appendix C-1 .

h. Standard Hardware for Mounting Signs or Information Boards

- Galvanized (as opposed to zinc plated) lag screws and washers should be used to minimize corrosion.
- Decking screws can be used to mount small metal signs to posts. To avoid corrosion, ceramic coated screws should be used.

- For wood signs or large metal signs attached to posts, ¼" x 3" galvanized lag screws should be used.
- For wood signs, information boards, or large metal signs attached to trees, use 5/16" lag screws sufficiently long to penetrate about 2" into the tree.

i. Survey Tape

Specific colors are used for specific purposes.

- Orange is used only to mark trees that are to be removed or to mark boundary lines.
- Light green tape should be used to mark work areas other than tree removal.
- For laying out routes for new or relocated trails, pink-glo tape is recommended. The standard colors for blazing can also be used; i.e., white, yellow, or blue.
Note: blue is not particularly visible and is not recommended.
- Once tape has served its purpose, it should be removed.

Pressure-Treated Lumber

Pressure-treated lumber is required for various structures; e.g., bridges, kiosks, and mini-kiosks. Quoting from the EPA web-site: “Chromated copper arsenate (CCA) is a chemical wood preservative containing chromium, copper and arsenic. CCA is used in pressure treated wood to protect wood from rotting due to insects and microbial agents. EPA has classified CCA as a restricted use product, for use only by certified pesticide applicators.” This type of lumber must not be used for any structures described in this manual. This also means that recycled pressure-treated lumber of unknown origin cannot be used.

Bridges

The CLMC will approve all proposals for the location and design of bridges on town conservation land.

Bridges must be designed to accommodate the expected usage, (e.g., hikers, mountain bikers, snowmobilers, horses), and be appropriate for the location.

1. Small Bridges

- Cross small steams, shallow gullies or wetlands:
- See construction details for small bridges suitable for hikers or mountain bikers in Appendix D-6.

2. Medium to Large Bridges

- Cross significant streams or deep ravines
- Carry heavy loads; e.g., horses, snowmobiles
- Snowmobiles need 40" width
- Horses prefer 4-5' width & railings
- See references in appendix A-1 or A-2 for construction information.

The following table provides a guide for selecting beams for bridges over a range of spans. The table is intended for bridges for hikers, not for bridges intended to support heavy vehicles.

From Trail Building and Maintenance, 2nd Edition
 Robert D Proudman and Reuben Rajala; Published by the AMC (now out-of-print)

BEAM SPAN TABLE

BEAM SIZE	SINGLE BEAM		DOUBLE BEAM	
	Maximum Span	Maximum Cantilever	Maximum Span	Maximum Cantilever
4"	6'	2'	8"	3"
5"	9'	3'	12'	4'
6"	12'	4'	14'	5'
7"	15'	5'	18'	6'
8"	18'	6'	22'	7'
9"	21'	8'	25'	8'
10"	25'	9'	29'	9'
12"	32'	10'	37'	12'
14"	39'	11'	45'	13'
16"	47'	14'	54'	16'
18"	55'	16'	63'	18'
4" x 4"	8'	3'	10'	4'
4" x 4"	12'	4'	15'	5'
4" x 8"	17'	5'	20'	6'
6" x 4"	10'	3'	12'	4'
6" x 6"	15'	5'	17'	6'
6" x 8"	20'	6'	23'	8'
6" x 10"	25'	8'	29'	10'
6" x 12"	30'	10'	35'	12'
8" x 4"	11'	4'	13'	4'
8" x 6"	17'	6'	19'	6'
8" x 8"	22'	7'	25'	8'
10" x 4"	12'	4'	14'	5'
10" x 6"	18'	6'	21'	7'
10" x 8"	24'	8'	28'	9'
10" x 10"	30'	10'	34'	11'
10" x 12"	36'	12'	41'	13'

from the *Trail Manual of the Florida Trail*

Poison Ivy Control

Poison Ivy is a major problem on some trails. State of NH rules specify that herbicides can only be applied by licensed applicators. The only exception to this rule is that individuals can apply herbicides on their own property.

Section VI: Volunteers

Whenever possible, volunteers will be utilized for trail projects. Trail projects are identified by Trail Stewards or by a CLMC survey of the trails. Forms for reports by Trail Stewards or CLMC Surveys can be found at the end of this section. The CLMC will prioritize maintenance projects based on the reports, trail conditions, and available work and financial resources. The CLMC will manage the execution of maintenance and building projects.

Management of trails on Milford land would not be possible without dedicated volunteers. The accessibility and quality of Milford trails can be maintained most effectively with a skilled cadre of volunteers.

Trail volunteers will automatically become members of the Milford Trails Committee and will be registered as such with the Town.

Safety: Safety is the primary factor for anyone working on Milford Conservation Land.

1. Volunteers shall not work alone.
2. Volunteers shall not attempt work beyond their skill level.
3. Volunteers shall wear clothing appropriate to the work they will be performing.
4. Volunteers shall maintain good footing while using tools.
5. Volunteers shall maintain a clean work area.
6. Volunteers shall work on small sections and complete the work by cleaning/clearing before moving to another section.
7. Volunteers shall be aware of others in the work area,
8. Adult workers should provide guidance to younger workers to insure the safe operation of tools and that these guidelines are being followed
9. At the conclusion of a work session, the area must be inspected to ensure safety of the trail users.

Management of Adult Volunteers

1. The Conservation Office or a member of the CLMC will maintain an Excel workbook with worksheets containing this information:
 - A list of active volunteers (including Trail Stewards), their contact information, date of last contact, skills, work and Town Forest preferences and availability.
 - A list of participation by volunteers in specific projects
 - A list of Town Forests or Trail Systems and the CLMC member and Trail Steward assigned to each.
 - A list of MCC members and their contact information.
 - A list of CLMC members and their contact information.
2. The CLMC will provide all volunteers with a copy “Guidance for Trail Stewards and Other Volunteers” (see copy in Appendix B-1). Volunteers shall be treated with respect and they should be utilized.
3. The CLMC will attempt to assign volunteers to projects that are appropriate for their skill levels and to work in areas in which they are interested.
4. The CLMC will provide volunteers with written or verbal directions to the location of the project.
5. The CLMC will provide volunteers with written instructions for the project.

6. The CLMC will provide guidance to a new volunteer or a new group of volunteers for their initial experience in maintaining trails.
7. When working on trails, volunteers must wear gloves and boots. Additional items they should consider having include: eye protection / long pants / tall socks / hard hat / sufficient water to remain hydrated / sun screen / bug – tick spray / Poison Ivy Soap®, Technu®, or a similar product to wash up after the project is finished .

Management of Youth Volunteers [These are regulation required by the Town insurer.]

1. Minors must have adequate training and be continuously supervised by adults in regards to safety.
2. Use of any power equipment is strictly forbidden.
3. Each young person must have all of the required and all of the recommended equipment listed in [7] above. Hard hats are recommended but are not required.

The CLMC will conduct a follow-up of trail work with the following intentions:

1. Inspect area to ensure that it has been left in a safe condition for trail users' safety.
2. Confirm work was completed as specified.
3. Update the work-to-be-done form if necessary.
4. Provide feedback to the volunteer(s) and send a thank you note.

Management of Volunteers from Organized Clubs

Snowmobile clubs, NEMBA, or other organizations which work on Milford Conservation Lands, need to send certificates of insurance naming the town of Milford as additionally insured and must do this every year. They do not need to submit all the member's names. The Town Insurer suggests that these organizations ask their insurers to automatically send the town a certificate of insurance each year when they renew their policies.

Section VII: Properties Managed by the CLMC

Properties	Acres	Notes
Mayflower Hill Town Forest	42	Northern half is the Patch Hill section (77 acres total)
Patch Hill section of Mayflower	35	New trail will connect w Amherst over Patch Hill
Tucker Brook Town Forest	285	Tucker Brook falls, variety of habitat
Hitchiner Town Forest	194	Pavilion, fields, Burns' Hill
Mile Slip Town Forest	452	Mitchell Brook, Badger Hill, cellar holes
Rotch Wildlife Preserve	40	Has one trail, wildlife observation
Granite Town Rail-Trail	29	3 miles, connects to Rail-Trail in Brookline
Souhegan River Trail	~3 miles	Small sections at each end have been constructed.

CLMC Properties with Trails

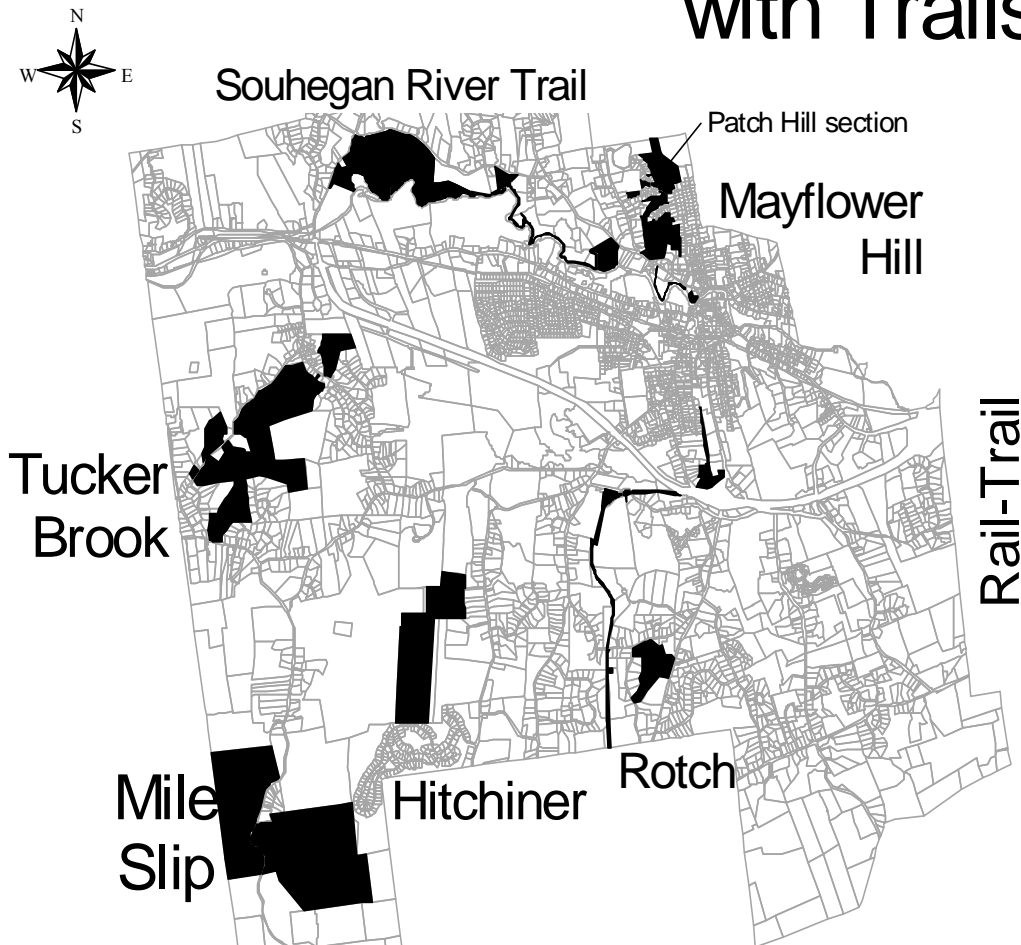

Management of Town Forests or Trail Systems by CLMC Members

Each Town Forest or “Trail System” may have one or more sections, depending upon the size of the parcel and the number of trails on that parcel. CLMC members are assigned responsibility for management of trails in specific Town Forests or for specific sections of Trail Systems.

A. Developed Trails or Trail Systems

Supervision of each developed trail or section will be assigned to one member of the CLCM. Each member is likely to be responsible for more than one trail or section.

Each trail or section will have just one Trail Steward who will report to the CLMC member assigned to that trail or section.

The responsibilities of the CLMC member for his / her assigned section include:

- When the Steward is first assigned to a section, walk that section with the new Steward to acquaint him / her with that section and show examples of the trail-work that is expected of the Steward.
- Maintain a “To Do List” for that section and provide the Steward with a current copy.
- Request and receive Spring and Fall trail reports from the Trail Steward.
- Forward a copy of these reports to the MCC office for central filing.
- Give feed-back to the Trail Steward after each report is received.
- As appropriate, add items from the Spring and Fall reports to the To Do List.
- Keep the Steward informed of new information pertinent to the section.

Note: The responsibilities of the Stewards are specified in § VI.

B. Un-Developed or Poorly Maintained Trails or Trail Systems

Two or more CLMC members may be assigned to develop a new trail or to up-grade a poorly maintained trail or trail system.

At an appropriate point in the development, a new Steward may be recruited for each section to help with the work and to eventually take over that section.

Once the section is at or close to meeting CLMC standards as defined in this Trails Manual, the specifications per § A above apply.

Section VIII: Maps

Trail Maps

Trail maps are produced by the Milford Conservation Commission staff using *ArcView* software. Trails will eventually be one of the layers in the Milford GIS system.

1. Types of maps and distribution

- Maps for general distribution will generally be printed on 8-1/2 x 11” paper in black & white. These will be made available to the public at no cost.
- Maps for use in Kiosks may be printed on larger paper and in color.

- Maps for general distribution will be available in the entryway to the Community Development Department in the Town Hall on Nashua Street. Maps will be placed in Kiosks and Information Boards on the various properties.
2. Specifications for all maps
 - Contour lines printed with a light but readable density will be used in the background of all maps.
 - All posted maps will have a “You Are Here” indicator made from 3M Temflex electrical tape, 1700C Yellow, with “You Are Here” written with a fine Sharpie black pen.
 3. Information to be included on all maps
 - A Legend
 - The roads bordering the property
 - The trails maintained by the CLMC
 - Streams, open water, and wetlands
 - Features of interest such as waterfalls, stone walls, stone structures, views, old quarries, historical sites, etc.
 - Magnetic and true North orientation
 - Date of last revision
 - Distance scale
 - Topographic line scale

4. Information to be included on Asset maps

One map will be prepared for the MCC office which shows the location of specific assets on each trail or section of a Trail System. This map may be prepared by the CLMC supervisor for that section from data supplied by the Trail Steward or from other sources. This map will eventually be used in a layer on the GIS system. It is preferable to get GPS coordinates for each asset.

The assets to be included are:

- Kiosks and Mini-Kiosks
- Information Boards
- Bridges
- Routed signs
- All metal signs except directional signs.
- Benches

Section IX: Storage Shed

The MCC owns a storage shed which is located on Lovejoy Road. This is used to store tools, lumber, hardware, signs, paint, and other supplies owned by the MCC.

Water-based paints and adhesives should not be stored in the shed but water-based herbicides can be stored there.

An inventory of stored items will be maintained by the MCC Office.

A clipboard will be hung in a prominent place inside the shed. Items should be checked out when taken and checked back in when returned. If items are to be consumed, that should be noted on the clipboard.

Appendix A: References/Sources

Section A-1: Source Materials

1. The Complete Guide to Trail Building and Maintenance, 3rd Edition
Appalachian Mountain Club Books, Boston, Massachusetts; Carl Demrow & David Salisbury
ISBN No. 1-878239-54-6 (Wadleigh Library call number: 634.93 Dem)
2. Managing Mountain Biking - IMBA's Guide to Providing Great Riding
International Mountain Biking Association, Pete Webber, editor
ISBN No. 978-0-9755023-1-X
3. Trail Solutions – IMBA's Guide to Sweet Singletrack
International Mountain Biking Association, 2004
ISBN No. 0-9755023-0-1 (Wadleigh Library call number 634.93Fel)
4. Best Management Practices for Erosion Control During Trail Maintenance and Construction;
STATE OF NEW HAMPSHIRE, Department of Resources and Economic Development,
Division of Parks and Recreation, Trail Bureau, 1996
5. Trail Construction and Maintenance Notebook, USDA, Forest Service, Technology and Development Program, (MCC Office)
6. Footpaths – a practical handbook, Elizabeth Agate, Revised edition April 1996, BTCV (British Trust for Conservation Volunteers); ISBN No. 0 946752 31 1 (MCC Library)

Section A-2: Other Useful References or Sources of Information

1. Books or other documents
Maine Trails Manual; Guidelines for Recreational Trail Construction; Maine Dept. of Conservation, Bureau of Parks and Land (MCC Office) [has information on bridge construction]
2. Organizations
 - Trail Wrights
 - NH Division of Parks & Recreation – Trails Bureau
 - NH Fish & Game Dept.
3. Web Sites
 - Town of Milford home page: <http://milfordnh.info/milford/index.htm>
 - Milford Conservation Commission homepage: <http://conservation.milfordnh.info/> contains a great deal of information about the Conservation Commission and its many functions. Trail maps, meeting minutes, town and state documents and much more can be viewed on the site.
 - Link to this Trails Manual:
http://conservation.milfordnh.info/pdf_docs/MCCTrailsManual.pdf
 - NH Fish & Game's OHRV page – includes links and contacts for ATV and snowmobile clubs, current lists of rules and regulations.

- <http://www.wildlife.state.nh.us/OHRV/ohrv.htm>
- NH Trails Dept. home page – includes rules and regulations, links to ATV and snowmobile club pages, and current maps of trails.
<http://www.nhtrails.org/>
 - Chapter 215-A of the NH Statutes covering OHRV use and trails. Also see Chapters 482-A and 485-A pertaining to wetlands.
<http://www.gencourt.state.nh.us/rsa/html/NHTOC-215-A.htm>
 - VOSS Signs hope page: <http://vosssigns.com>

Appendix A-3: Grade / Slope Angle Conversion Table

Percent Grade	Decimal Grade	Slope Angle	Percent Grade	Decimal Grade	Slope Angle
1.0%	0.010	0.6 deg	51.0%	0.510	27.0 deg
2.0%	0.020	1.1 deg	52.0%	0.520	27.5 deg
3.0%	0.030	1.7 deg	53.0%	0.530	27.9 deg
4.0%	0.040	2.3 deg	54.0%	0.540	28.4 deg
5.0%	0.050	2.9 deg	55.0%	0.550	28.8 deg
6.0%	0.060	3.4 deg	56.0%	0.560	29.2 deg
7.0%	0.070	4.0 deg	57.0%	0.570	29.7 deg
8.0%	0.080	4.6 deg	58.0%	0.580	30.1 deg
9.0%	0.090	5.1 deg	59.0%	0.590	30.5 deg
10.0%	0.100	5.7 deg	60.0%	0.600	31.0 deg
11.0%	0.110	6.3 deg	61.0%	0.610	31.4 deg
12.0%	0.120	6.8 deg	62.0%	0.620	31.8 deg
13.0%	0.130	7.4 deg	63.0%	0.630	32.2 deg
14.0%	0.140	8.0 deg	64.0%	0.640	32.6 deg
15.0%	0.150	8.5 deg	65.0%	0.650	33.0 deg
16.0%	0.160	9.1 deg	66.0%	0.660	33.4 deg
17.0%	0.170	9.6 deg	67.0%	0.670	33.8 deg
18.0%	0.180	10.2 deg	68.0%	0.680	34.2 deg
19.0%	0.190	10.8 deg	69.0%	0.690	34.6 deg
20.0%	0.200	11.3 deg	70.0%	0.700	35.0 deg
21.0%	0.210	11.9 deg	71.0%	0.710	35.4 deg
22.0%	0.220	12.4 deg	72.0%	0.720	35.8 deg
23.0%	0.230	13.0 deg	73.0%	0.730	36.1 deg
24.0%	0.240	13.5 deg	74.0%	0.740	36.5 deg
25.0%	0.250	14.0 deg	75.0%	0.750	36.9 deg
26.0%	0.260	14.6 deg	76.0%	0.760	37.2 deg
27.0%	0.270	15.1 deg	77.0%	0.770	37.6 deg
28.0%	0.280	15.6 deg	78.0%	0.780	38.0 deg
29.0%	0.290	16.2 deg	79.0%	0.790	38.3 deg
30.0%	0.300	16.7 deg	80.0%	0.800	38.7 deg
31.0%	0.310	17.2 deg	81.0%	0.810	39.0 deg
32.0%	0.320	17.7 deg	82.0%	0.820	39.4 deg
33.0%	0.330	18.3 deg	83.0%	0.830	39.7 deg
34.0%	0.340	18.8 deg	84.0%	0.840	40.0 deg
35.0%	0.350	19.3 deg	85.0%	0.850	40.4 deg
36.0%	0.360	19.8 deg	86.0%	0.860	40.7 deg
37.0%	0.370	20.3 deg	87.0%	0.870	41.0 deg
38.0%	0.380	20.8 deg	88.0%	0.880	41.3 deg
39.0%	0.390	21.3 deg	89.0%	0.890	41.7 deg
40.0%	0.400	21.8 deg	90.0%	0.900	42.0 deg
41.0%	0.410	22.3 deg	91.0%	0.910	42.3 deg
42.0%	0.420	22.8 deg	92.0%	0.920	42.6 deg
43.0%	0.430	23.3 deg	93.0%	0.930	42.9 deg
44.0%	0.440	23.7 deg	94.0%	0.940	43.2 deg
45.0%	0.450	24.2 deg	95.0%	0.950	43.5 deg
46.0%	0.460	24.7 deg	96.0%	0.960	43.8 deg
47.0%	0.470	25.2 deg	97.0%	0.970	44.1 deg
48.0%	0.480	25.6 deg	98.0%	0.980	44.4 deg
49.0%	0.490	26.1 deg	99.0%	0.990	44.7 deg
50.0%	0.500	26.6 deg	100.0%	1.000	45.0 deg

Appendix B: Guidance document for trail stewards and other volunteers / Reports / Checklists

Copies of these documents appear in the following pages. Formal copies for use may be picked up from the MCC office or may be mailed or e-mailed from the MCC office in the town hall.

Appendix B-1: GUIDANCE FOR TRAIL STEWARDS AND OTHER VOLUNTEERS:

This document is to be provided to each Trail Steward and may be given to Trail Volunteers.

Appendix B-2: TRAIL REPORT FORMS Trail Stewards are expected to provide a Spring and a Fall report for their chosen trail.

Appendix B-3: SPRING TRAIL SURVEY FOR TRAIL STEWARDS

Appendix B-4: CHECKLIST FOR BACKBACK / TRAIL SUPPLIES

Appendix B-5: TRAIL SURVEY CHECKLIST The CLMC surveys specific conservation properties. The Trail Survey Checklist is used for such surveys to record their findings. As appropriate, abutters or other persons may be invited to participate. The original is in MS Excel and is the more useful software for this purpose.

Appendix B-1

GUIDANCE FOR TRAIL STEWARDS AND OTHER VOLUNTEERS

The Conservation Lands Management Committee (CLMC) greatly appreciates your willingness to help maintain trails in our town. The trails in each Town Forest or properties under the auspices of the MCC, or sections of trails in the larger properties, are managed by specific members of the CLMC. Volunteers will be assigned to specific trails or sections of trails and will interface with the CLMC member responsible for your trail. It is the expectation that all trails in Milford will be maintained to the same standards. This document describes our expectations of Trail Stewards as well as the basic standards that the CLMC has developed for our town trails. As we all gain further experience, these standards may be modified. Your suggestions for such changes will be most welcome.

Duties of Trail Stewards

Trail Stewards are expected to walk their assigned trail(s) or sections at least twice a year; once in the spring to clear winter debris, and once again in the fall. During these walks you should do whatever work is within your capabilities to clear the trail of obstructions, control drainage, to repaint faded blazes, and to inspect the condition of parking areas, kiosks, signs and blazes, and to note any conditions which impact the public's use of the trail.

Reports are expected from each Trail Steward in the spring (by May 1), and again in the Fall (by November 1) - copies are appended. These reports may be submitted by e-mail or regular mail to your CLMC contact.

Trail Stewards shall not operate power tools, open new trails, nor do any major work such as installation of water-bars or building bridges. The CLMC will assemble teams to handle such projects. Exceptions to these rules may be given by the CLMC in specific situations.

Standards for Maintaining *Natural* Trails in Milford

Most of our trails are "Natural" hiking or bicycle trails; i.e., they are on natural soils and generally are not covered with stone dust, asphalt, or other materials that are not natural to the site.

- **The Trail:** The pathway should be cleared of all obstructions from a minimum width of 4' and to a minimum height of 8'. Small trees growing in the path should be cut at ground-level. Branches should be cut with loppers or a saw at the trunk rather than just broken off. Axes should not be used to cut limbs since they will nearly always damage the tree. Brush should be pulled off the trail to a distance of at least 10' and put into small piles. Litter needs to be removed from the property. Report large items that you are unable to remove alone; e.g., parts of vehicles, sofas, tires, etc. The CLMC will make arrangements for their removal.
- **Marking Trees:** We suggest that you carry orange survey tape with you during your inspections. Dead trees or other obstructions that may need to be removed can be marked with this tape so that they can be easily located later. Also, in the winter, snow and ice make branches of evergreens (especially Hemlocks) hang much lower than usual. It is helpful to walk your trail or section just after a heavy snow. These low-hanging branches can be marked with this orange tape so that they can be located and pruned later in the year.
- **Tools:** The tools which will generally be needed to cut trees and branches include pruning shears, loppers, small hand saws, bow-saws, and pole saws for the higher limbs. As previously stated, the use of axes is discouraged. Some hand-tools can be borrowed from the Milford Conservation Commission.
- **Blazes:** The colors for blazes are: White for the main trail, Blue for side trails that loop back onto the main trail, and Yellow for trails that connect to the main trail but lead to secondary trail-heads.

The trails should already be blazed; however, you may find some blazes are missing or lacking in certain places, and others may be old and obscure. Please note such conditions in your reports. You are encouraged to repaint old blazes but should not add new ones. Paint and brushes for blazing will be supplied by the MCC. Please do not use any other paint.

The area where a blaze is to be repainted should first be cleaned with a wire brush or paint scraper to remove loose debris and to smooth rough bark. Blazes should be a rectangle 2" x 6" and painted carefully to give sharp edges.

Metal diamond-shaped markers in each of the three colors are available to use at the beginning of trails or where sharp turns occur. If these are missing or if you believe more of these signs are needed, please note this in your reports.

- Erosion Control: Storm water must not be allowed to erode the trails. Storm water control devices such as drainage ditches and water bars will need to be cleaned periodically. If erosion or ponding is observed on your trail, it is important to note the location and to include these observations in your report. It is helpful to mark areas where ponding is occurring with green survey tape (to be provided by the MCC) so that this area can be located in the dry season.

The best time to check for areas where erosion is beginning is during a heavy rain. This is when water flowing down a trail can best be observed.

Thank you very much for helping us keep our town's trails clear and safe. Remember to send in those two trail reports. If you find that something needs immediate attention, please contact the MCC using the contact information at the end of each trail report form.

The Milford Conservation Land Management Committee

Appendix B-2

SPRING TRAIL REPORT

Please use this form to report the findings of your spring patrol/inventory of your trail system or trail section. This information may be used to help plan future projects. Include details of any recent work. **Please return this form by May 1. THANK YOU!**

Property name and trail section for which you are a trail steward:

Your name:

Date of spring walk-over:

Condition of parking lots at trail-heads:

Kiosks, Mini-Kiosks, Information Boards, and bridges - condition and / or adequacy of structure:

Kiosks, Mini-Kiosks, Information Boards: condition of displayed documents

Condition of trail:

Problems requiring a work crew [e.g., chain saw work, brush-hog, erosion issues, etc.]:

Condition of blazes [note if replacements or new blazes at specific points are needed]:

Signs: condition or places where new signs are needed:

Evidence of incursions onto Milford Conservation Lands [e.g., ATV use, trash, private trails that enter or cross Milford Town trails, etc.]:

Contacts with hikers or landowners of adjacent properties:

Other issues:

Please send the completed form by either e-mail or regular mail to your CLMC contact.

FALL TRAIL REPORT

Please use this form to report the findings of your fall patrol/inventory of your trail system or trail section. This information may be used to help plan future projects. Include details of any recent work. **Please return this form by November 1. THANK YOU!**

Property name and trail section for which you are a trail steward:

Your name:

Change in address, telephone no., or E-mail:

Work done this year:

Date of fall walk-over:

If there is nothing new to report below, simply enter "see Spring Report".

Condition of parking lots at trail-heads:

Kiosks, Mini-Kiosks, Information Boards, and bridges - condition and / or adequacy of structure:

Kiosks, Mini-Kiosks, Information Boards: condition of displayed documents

Condition of trail:

Problems requiring a work crew [e.g., chain saw work, brush-hog, erosion issues, etc.]:

Condition of blazes [note if replacements or new blazes at specific points are needed]:

Signs: condition or places where new signs are needed:

Evidence of incursions onto Milford Conservation Lands [e.g., ATV use, trash, private trails that enter or cross Milford Town trails, etc.]:

Contacts with hikers or landowners of adjacent properties:

Other issues:

Please send the completed form by either e-mail or regular mail to your CLMC contact.

Appendix B-3

SPRING TRAIL SURVEY FOR TRAIL STEWARDS

The information listed below is a guideline of the issues that should be checked during Spring time for the trail systems on our Conservation Lands/ Town Forest. Please add this info to your specific “To Do List” with any other additional issues you discover.

- Check for missing signs, damaged signs or direction arrows and signs that were tampered with. This includes TF signs, metal trail signs, routed signs, property signs, LCIP signs, trailhead parking signs hiker signs and the post that support any sign.
- Remove any unauthorized signage.
- Check blaze conditions and check to see if trees that had a blaze on them didn't fall to the ground.
- Check the condition of trailhead parking areas and remove debris.
- Check the integrity of pavilions, building structures, kiosk, benches, picnic tables for damage due to the elements, vandalism and rotting wood.
- Check to see if large boulders/ logs and gates are still in place that were located to keep vehicles out.
- Check areas that had a scenic view or clearing and make sure they still have an unobstructed view of the same.
- Check to see if any man made or natural surfaces, need to be replaced, re-surfaced, painted or repainted due to graffiti.
- Remove any fallen trees or fallen branches that cross a trail. Also identify standing dead trees that have the potential to fall across a trail. Check for widow makers and branches that hang low in the path of travel.
- Check the integrity of all footbridges and look for planks or beams that need to be repaired or replaced.
- Identify trail problems and location issues that might warrant re-routing a trail, due to severe wash-out or numerous obstructions that can't easily be removed.
- Inspect kiosk and info boards for condition and map/ literature needs. Spray penetrating oil in locks and test.
- Identify if a specific location on a trail will need a footbridge added, due to the issue of water or a seasonal stream.
- Remove ALL debris and trash on and around the trails, at points of interest, at landmarks and at trailhead locations.
- Identify ponding and erosion issues.
- The breaking down of and the dismantling of fire pits/ campfire locations.

Appendix B-4: Checklist for Backpack / Trail Supplies

Checklist for Backpack / Trail Supplies

CLMC members and Trail Committee workers doing trail work should find that the listed supplies are very beneficial to have on the trail with them, in a backpack, or carrying with them for the indicated job. Work equipment will be provided for specific jobs. Examples include trail signs, post driver, blaze paint, nails, First-aid kit.

Basic: (Items that could be put in a backpack)

Map: Map of the trail system you will be on.

Flagging Tape : White, Blue and or Yellow (needed if identifying new trails). Orange: to identify tree(s) to be cut down.

Gloves

Safety Glasses

Pruners

Trowel: To remove animal scat from the trail.

Scraper: To prep bark for a blaze or to remove unwanted blazes.

Trash Bag(s)

Pocket Knife

Bug Spray

Note Pad & Pen

Water

Job Specific (in addition to the basic supplies)

For Blazing Trails:

Paint Brushes

Wire Brush

Paint

Spray Paint: (Brown & Gray to cover unwanted blazes on bark that can't be scraped)

Rags

Screw Driver

Scraper Blades

Latex/ rubber gloves: (disposable)

Trail Sign Installation/ Removal: (in addition to the basic supplies)

Hammer: With a claw.

Post Hole Digger: If post for a sign is needed

Shovel: If post for a sign is needed

Pry Bar: For post hole digging

Ratchet, Sockets & Wrenches (1/4 & 5/16": Needed for installing signs.

Screw Driver: A multi-head unit that includes these heads: slotted, Phillips, #2 square, and star

Level

Tape Measure

Making NEW Trails: (in addition to the basic supplies)

Rake: Metal & leaf rake

Shovel

Hand Saw/ Pole Saw

Loppers

Optional Items: Cell Phone, Digital Camera, 2-Way Radios

Appendix B-5: Image of *Standard Checklist for Trail Survey*

Note: This document is intended for use by CLMC members

Note: The original is in MS Excel

Standard Checklist for Trail Survey

Trail System Inspected:

Inspecting Team Members:

Date of Inspection:

Date of this revision: 22 February 2008

Issue		Comments
1	Inspect kiosk and Information Boards for condition and literature needs; check condition of locks	
2	Check all signs for damage and accuracy	
3	Check trailhead parking areas	
4	Check Blaze conditions	
5	Clearings that need brush or tree removal (e.g., to maintain views)	
6	Fallen or dead tree removal	
7	Trail clean-up (i.e., trash removal)	
8	Footbridge inspection / repair	
9	Need for new footbridges	
10	Trail erosion / water problems	
11	Locating & identifying property boundaries / re-painting needs	
12	GPS of trails to develop better and more accurate maps	
13	Identify trail problems and location issues that might warrant re-routing the trail	
14	Inspect any benches for damage or integrity issues	
15	If there are buildings or picnic tables on the property, check for condition. Note if any surfaces need to be resurfaced or painted.	
16	List any additional issues to this specific Town Forest / Hiking Trail System	

Appendix C: Graphics

Appendix C-1: Metal Signs

	<p>1. WHITE DIRECTIONAL SIGN</p>		<p>10. OHRV TRAILS CLOSED</p>
	<p>2. BLUE DIRECTIONAL SIGN</p>		<p>11. OHRV PARKING</p>
	<p>3. YELLOW DIRECTIONAL SIGN</p>		<p>12 STOP –LEAVING PULIC TRAIL</p>
	<p>4. CONSERVATION BOUNDARY</p>		<p>13. STAY ON TRAIL</p>
	<p>5. LARGE HIKER SIGN</p>		<p>14. LCIP SIGN</p>
	<p>6. SMALL HIKER SIGN (12"X 12")</p>		<p>15. SOHEGAN RIVER TRAIL</p>
	<p>7. MWV NOT ALLOWED</p>		
	<p>8. NO MOTORIZED VEHICLES</p>		
	<p>9. TRAIL HEAD PARKING</p>		

Blazes Used On Milford Public Trails

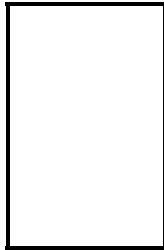

White

**Main Trail - Starting at
Primary Trail Head**

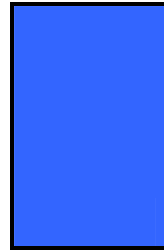

Blue

**Loop off of and
Connecting Back to the
Main White Trail**

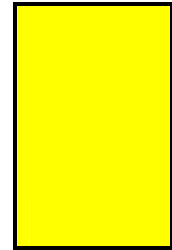

Yellow

**An Existing Trail
Connecting to a
Different Trail Head**

Metal Diamond Signs Indicate Direction



Left Turn Trail Straight Ahead Right Turn

Notice To Trail Users

For Any Emergency Situation – Dial 911

How You Can Help

- Keep Pets On A Leash
- Pick Up Branches On The Trail
- Carry Out What You Carry In
- Pick Up Trash
- Do Not Paint Blazes
- Do Not Cut New Trails
- Do Not Use Power Tools (Especially Chain Saws) In Milford Town Forests
- Report Any Problems You Encounter Or Suggestions You Care To Offer Regarding Trails To The Milford Conservation Commission – The Contacts Are:

Telephone: 603-249-0628 (please leave a message)

E-Mail: concomm@milford.nh.gov

Appendix C-3: Brush Piles for Wildlife

From Wildlife in Connecticut; Wildlife Habitat Series No. 2
Connecticut Department of Environmental Protection, Wildlife Division

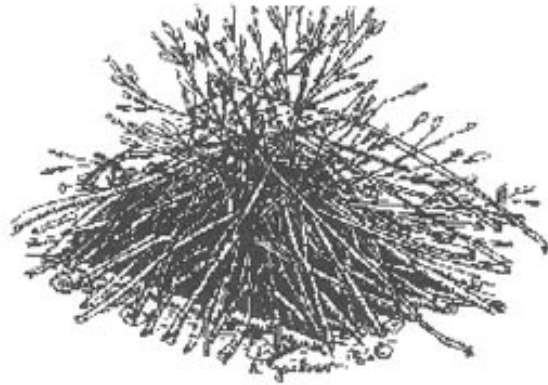
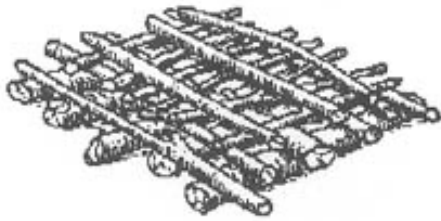

General Information

Wildlife have four basic requirements: cover, food, water and living space. Each must be present in an animal's habitat. Cover is the protective element within the habitat which may come in different forms for various wildlife species. It may be a hedgerow for rabbits, a young hemlock thicket for deer, a spruce tree for a golden-crowned kinglet or a brush pile for small mammals and birds. Whatever form cover takes, it contributes to one or more of the necessary functions in the lives of animals: breeding, nesting, hiding, resting, sleeping, feeding and traveling.

When natural cover is limited in wildlife habitat, brush piles may be provided. If possible, brush piles should be a by-product of other land management activities, rather than a specific practice. Timber harvest, timber stand improvements, pasture or cropland clearing, and firewood cutting all provide woody limbs suitable for brush piles.

Location of Brush Piles

Brush piles benefit wildlife most when they are located at the edges of forest openings. They should not be further than 10 feet from the woodland border. Other suitable locations for

brush piles are along road edges, streams, marshes and yard borders within or next to woodlands.

Four to eight brush piles per acre, spaced 100 to 150 feet apart, is a sufficient amount and will supply the needed cover requirements for most wildlife species.

Construction of Brush Piles

Materials used in brush piles will depend largely on what is available. Oak, locust and other hardwoods which are rot resistant make durable bases. Other suitable materials include large stumps, cull logs, old fence posts and stones. The largest material should form the base and layers of smaller limbs and branches should be added as filler.

Brush piles are usually mound- or tepee-shaped. Ideally, they should be six to eight feet high and 15 feet in diameter. An alternate method of providing cover is to windrow the brush along a stone wall or woods' edge. In this case, brush should be piled in one direction with the tops facing the edge of the woods. Covering brush piles and windrowed brush with evergreen boughs will provide wildlife with additional cover.

Brush piles are short lived (six to eight years). In order to provide continual cover, new ones should be developed periodically.

Benefits

When properly constructed and located, brush piles can benefit many species of wildlife, including bobwhite quail, cottontail rabbits, ruffed grouse, wild turkeys, skunks, raccoons, opossums, woodchucks, chipmunks, mockingbirds, white-throated sparrows and juncos. Predators such as foxes, bobcats, hawks, owls and coyotes benefit from the small mammal and bird populations found in or around brush piles.

Grasses, forbs and vines, which are highly valuable to wildlife, will grow up through brush piles and add density and permanence to the piles.

Caution should be taken when creating brush piles in densely populated areas, for they may lead to nuisance wildlife problems. Skunks, opossums and raccoons will, on occasion, live in or under these brush piles and may cause a nuisance situation for nearby homeowners.

Glossary

Cull trees, logs or lumber which have been rejected because they do not meet certain specifications.

Forb any herbaceous plant species other than those in the grass, sedge and rush families; fleshy leaved plants.

Stand plant communities, particularly of trees, sufficiently uniform in composition, constitution, age, spatial arrangement or condition to be distinguishable



from adjacent plant communities; may delineate a silvicultural or management entity.

Timber stand improvement the use of methods, such as thinning, firewood cutting and selection cutting, to improve the growth and condition of a stand of timber.

References and Further Reading

Martin, C. O. and J. L. Steele, Jr. 1986. Brush piles, Section 5.3.1, U.S. Army Corps of Engineers wildlife resources management manual. 19 pp.

Yoakum, J., W. P. Dashmann, H. R. Sanderson, C. M. Nixon and H. S. Crawford. 1980. Habitat improvement techniques. Pages 329-403 in S. D. Schemnitz, ed., Wildlife management techniques manual, 4th ed. The Wildlife Society, Washington, D.C. 686 pp.

Appendix C-4: Trail Work Permit

A permit has been developed for contractors cutting trees on Town Forests and for Trail Volunteers working in these properties. The permit is encapsulated. This is a copy of that permit.



Milford Conservation Land Management Committee (CLMC)

Work Authorization



The CLMC has approved this individual or group of Trail Committee Members, Volunteers, Contractor or club/ organization to do work in this town forest or conservation land.

Such work may consist of, but not limited to: trail construction and maintenance, tree removal, sign installation, blaze painting, pruning and brush clearing.

CLMC

Appendix D: Construction Details

1- General Specifications

2- Kiosk, Large

3- Kiosk, Small

4- Information Board

5- Routed Signs: Town Forest Signs and Trail Signs

6- Small Bridges

7-Backing Plates for Metal Directional and Boundary Signs

1-General Specifications

All hardware that is exposed to the elements should be galvanized; e.g., lag and carriage bolts, nuts and washers, hinges.

All decking screws should be ceramic coated and have, preferably, #2 square drivers. Star drivers are acceptable but Phillips drivers are not.

For mounting signs to wooden posts, 1/4" lag bolts are satisfactory. For mounting signs to trees, 5/16" lags should be used.

Adhesives must be waterproof. Acceptable adhesives include epoxy, urethane glues (e.g., Gorilla Glue, 3M Marine 4200 or 5200), and Titebond III Ultimate Wood Glue. The latter is especially useful since un-cured glue easily cleans up with a damp sponge.

Some projects require a wood sealant. Use Cabot Clear Solution, Natural, No. 9200. The fumes are unpleasant - do not apply indoors.

2- Large Kiosk

The CLMC has adopted the following standard design for kiosks used on Milford conservation properties where a large amount of material needs to be displayed. The accompanying tips and photos may be helpful to those who may construct such kiosks.

Pressure treated 4"x4"s and 1/2" pressure treated plywood are almost always wet because the lumber yards store them outside. If possible, these materials should be purchased at least 2 weeks early and stored inside to dry. Stack the materials using spacers between layers, and allow several inches between boards so that sufficient air circulates around the materials to assist in the drying process. If materials cannot be dried inside, then make sure that all materials are fully covered by tarps or appropriate plastic to keep everything dry. A soft carpenter's pencil is the best way to mark these materials.

Two kiosks should be constructed at one time - this is the most efficient use of materials and time. The estimated time to construct two kiosks is 50 hours. This includes: acquiring materials, set-up, construction, painting, caulking, putting tools away, clean-up, and disposal of waste at the dump.

Table 2-A includes a materials list and cost for construction of two kiosks in October 2007.

The minimum power tools needed are: Table saw; Skil saw, electric drill, and a battery-powered driver. A 12" chop saw or sliding miter saw (and possibly a router) would be very useful. (Note: only a 12" saw can cut thru a 4"x4" timber in a single cut.)

Figure 2-A

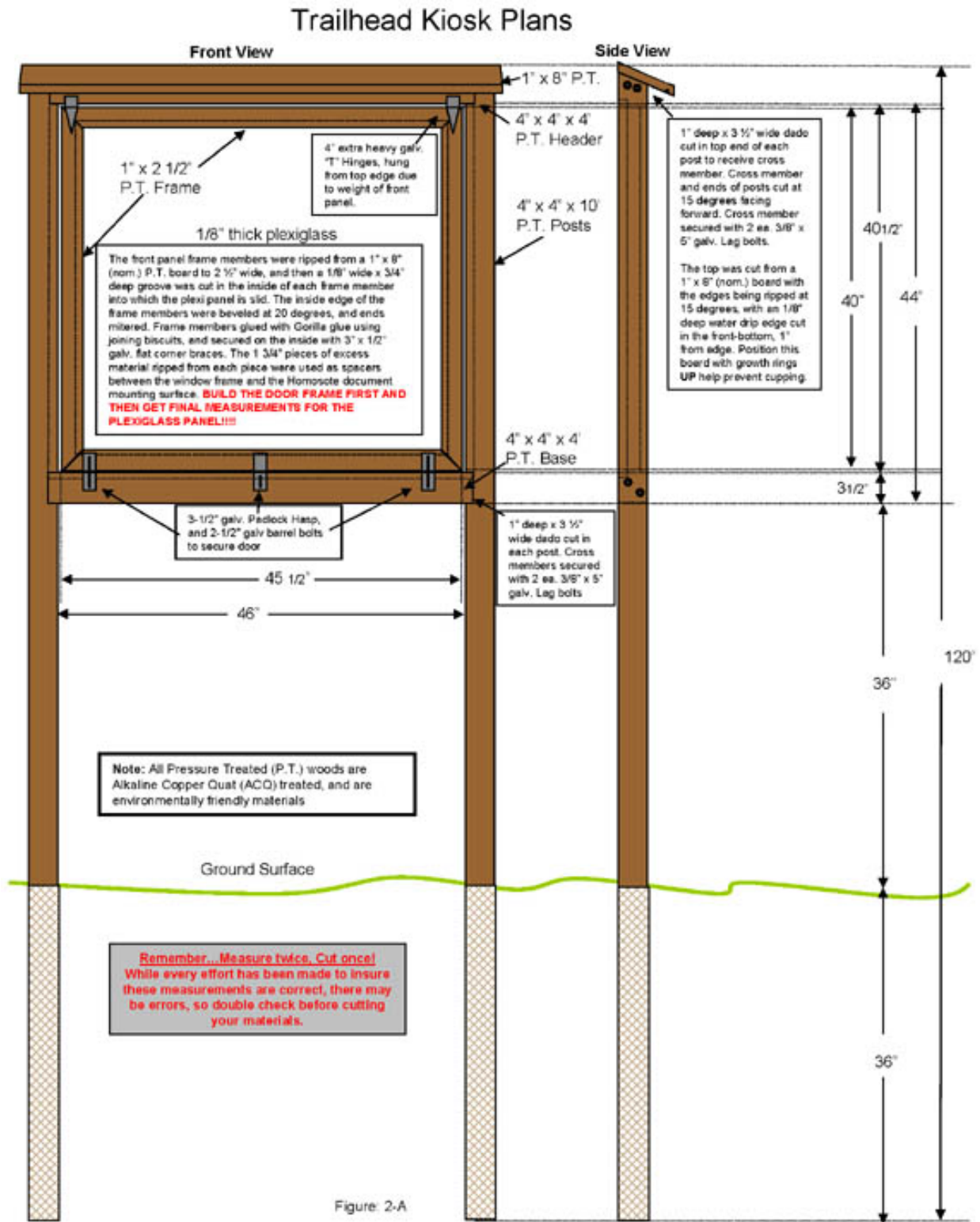

Figure 2-B

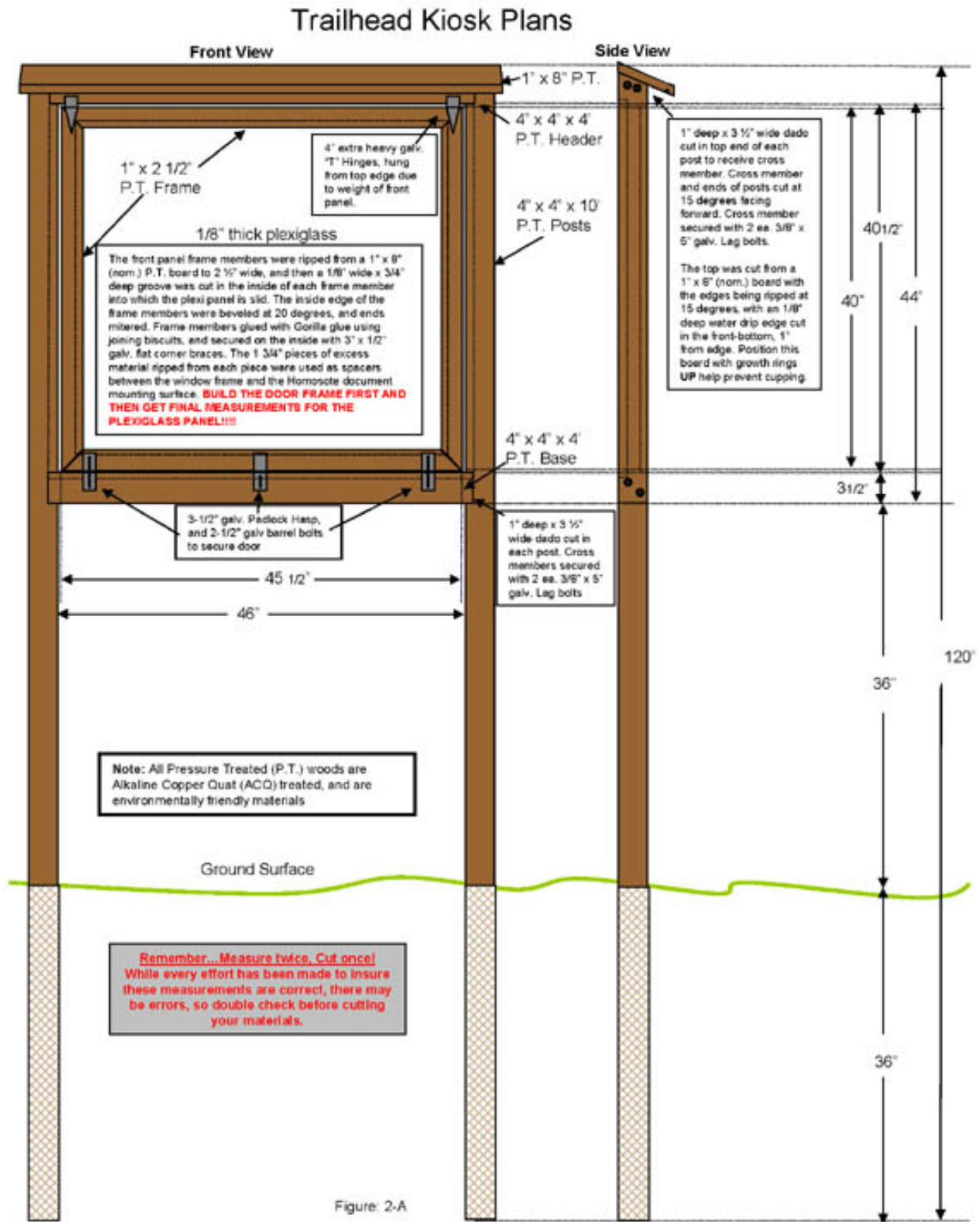

Table 2-A

Materials and Costs for Construction of Two Kiosks

Quantity	Item	F.N.	Cost Each	Total Cost	Use	Notes
Pressure Treated Lumber						
4	4 x 4 x 10'			\$41.60	Vertical side members	Cut one end at 10deg / cut two 1" daos
2	4 x 4 x 8'			\$16.64	Horizontal (cross) members	Cut each to 4'-0" Headers: cut one side at 10 deg Lower members: use as-is
1	1 x 8 x 12' D-Select boards	[1]		\$14.40	Roof	Bevel edges to 10 deg Rip water-drip groove on lower surface near front edge.
2	1 x 8 x 12' D-Select boards	[1]		\$28.80	Window frame and spacers	Rip [2] 2-1/2" strips for window frames. Rip excess strip to 1-3/4" to use as spacer between Homosote and window frame.
1	1/2" x 4' x 8' plywood			\$33.95	Back panel	Have mill cut to [2] 4' x 4' pieces
Other Sheet Stock						
1	1/2" x 4' x 8' Homosote			\$21.50	Mounting documents	Have mill cut to [2] 4' x 4' pieces. Cut to final size. Prime both sides and all edges. Paint all surfaces with 1 coat red enamel and front side with 2 coats.
1	1/4" x 4' x 8' Plexiglass	[2]		\$125.00	Window	
Hardware (Galvanized unless stated otherwise)						
16	3/8 x 5 lag bolts		\$0.85	\$13.60	Attach cross to side members	Draw diagonal on inside of groove - high side towards front/ top. Cut 7/16" holes at 1-1/4" in from corner.
16	3/8 washers		\$0.15	\$2.40		
4	4" extra heavy T hinge	[3]	\$7.49	\$29.96	Window	
4	2-1/2 barrel bolt		\$7.49	\$29.96	Window	
2	pkg of 4 - 3" flat corner braces		\$8.49	\$16.98	Window	Mount at 3/4" in from inner edges of frame.
2	3-1/4" padlock hasp		\$7.49	\$14.98	Window	
8	Fender washers, stainless steel		\$0.55	\$4.40	Attach Homosote to back panel	
2	Padlocks					To be provided by the MCC.
Other Materials						
2	tubes silicone caik		\$5.49	\$10.98	Windows and gaps	
1	quart exterior latex primer		\$10.41	\$10.41	Homosote	[1] 12' lengths were the only size available. Other lengths might be more efficient.
1	quart Moorglo Navajo White exterior enamel		\$10.41	\$10.41	Homosote	
1	bottle, 2 fl oz Gorilla Glue		\$0.00	\$0.00	Window mitered corners	[2] 4' x 8' pieces were the only size available. Other sizes might be more efficient.
	Disposal of waste at Milford dump			\$4.00		
				Sub Total =	\$429.97	
Boxes of Screws - Available for Future Kiosks						
1	box cement coated decking screws: 6 x 1-1/2"		\$3.49	\$3.49	Roof, window / Homosote spacers	[3] Light duty 5" strap hinges would be a better choice.
1	box cement coated decking screws: 8 x 2-1/2"		\$3.69	\$3.69	Window mitered corners	[4] Construction adhesive may be used instead.
1	box of 75: 8 x 1 pan head sheet metal screws, SS	[4]	\$5.99	\$5.99	Attach Homosote to back panel	[5] May not be needed.
1	box of 65: 10 x 3/4 flat sheet metal screws, SS	[5]	\$5.99	\$5.99	Hinges	
				Sub Total =	\$19.16	
				Total Cost =	\$449.13	
				Cost of each Kiosk =	\$224.57	

Prepared by Jon Thunberg

30 October, 2007

Construction Instructions / Tips / Photos

1. Cut the 8' 4"x4" timbers into 4' lengths.
2. On a table saw, cut the 15 deg. angle on the edge of the top 4' members. (Two mating cuts will be needed for blades less than 12".)
3. Cut the 15 deg. angle at the top end of each 10' vertical member.
4. To prepare for cutting the 1" deep slots in the side members, turn the members $\frac{1}{4}$ turn and align them as mirror images with the high top ends together (see Photo 2-3)



Photo 2-1: Cutting Grooves



Photo 2-2: Grooves cut



Photo 2-3: Alignment at top / grooves cut but not chiseled out. Clear the grooves with a wide chisel and a very coarse rasp.



Photo 2-4: Location of holes for lag screws

5. On each grooved surface, draw a diagonal line from the higher (front) to the lower (rear) corner. Make a mark about 1-1/4" in from each corner. Drill 7/16" holes for the lag screws.
6. Before the timbers are joined with the lag screws, cut the groove for the 1/2" thick back panel. On the back side of the upper timbers, first make a 1/2" deep cut 1" in from the inner edges where the back panel will be mounted. Then on the inner surface, make a joining 1" deep cut 1/2" in from the edge. Remove the 1/2" x 1" pieces of scrap. [Note: If a router is available with the proper bit, the members can first be joined with the lag screws and then the groove can be routed. The corners would have to be chiseled out.]
7. If needed, use shims (Photo 2-5) to make the front surfaces of the timbers even. Join the timbers with the lag screws.
8. Cut the back panel and check for fit. Be sure that the "good" side faces the back and that the "bad" surface faces forward (i.e., the Homosote panel should be attached to the "bad" surface).
9. Apply a silicone bead to the surface to which the back panel will be screwed. Attach the back panel using #6 1-1/2" decking screws.
10. Cut out the Homosote panels. Prime both sides and all edges. Paint all of these surfaces with exterior enamel. Give the front surface a second coat of enamel.
11. Attach the painted Homosote panel to the plywood backing (Photo 2-6). with #8 1" stainless steel pan-head sheet metal screws with stainless fender washers. (There is a stock of these screws and washers in the MCC storage shed.)
12. Screw the 1-3/4" spacers to the inner side of the window opening. (Pre-drill these spacers with 5/32" pilot holes.) Make sure that the upper edges are exactly 3/4" in from the upper surface to support the window frame.
13. Cut the roof boards to a length that will give a 2" overhang at each end. Check the growth rings on the end grain.  Make sure the growth rings form a "frown" (rather than a "smile") - this will minimize "cupping" of the roof board over time. Bevel each edge to 15 deg. Cut a shallow groove close to the front bottom edge of the roof boards. Attach the roof to the upper timber with decking screws.
14. Cut the window frames. Fit them to the opening in the 4" x4" timbers (Photo 2-6). Re-cut if necessary to give a clearance of about 1/16" - 1/8" all around.



Photo 2-5: Facing edges shimmed before vertical and cross members are joined with lag



Photo 2-6: Homosote screwed in place. Window frame in position supported by spacer scraps.

15. Make a mark on the back side of each of the 4 window frame pieces to be certain that this is the side where the grooves for the Plexiglass panel will be cut. These grooves should be $\frac{3}{8}$ " deep and about $\frac{1}{2}$ " wide. Use a narrow kerf blade when making these 2 cuts. Save the pieces that are cut out - they can later be used to hold the Plexiglass window in place.
16. If a biscuit cutter is available, the corners can be joined with biscuits.
17. Glue and clamp the corners.

Option 1 (if proper clamps are not available): Drill a $\frac{5}{32}$ " pilot hole at 1- $\frac{1}{4}$ " from the corner of each side of the side frame pieces. Counter-sink the holes. Apply glue to the mating corners. Slowly screw in the decking screw. Do not over-tighten since the mating pieces may slip. Tighten these screws after the glue sets (Photo 2-7). Repeat with the other 3 corners.



Photo 2-7: Mitered corners being glued with Gorilla Glue.

Wax paper is used to prevent adhesion to the wood clamping supports. Corners are joined with #8 x 2- $\frac{1}{2}$ " decking screws. $\frac{3}{16}$ " holes are drilled and countersunk at 1- $\frac{1}{4}$ " in from corner of the side frame members.

Option 2 (using corner clamps): Glue all corners, then clamp together using corner clamps..Photo 2-8 shows a corner web clamp being used for this purpose.

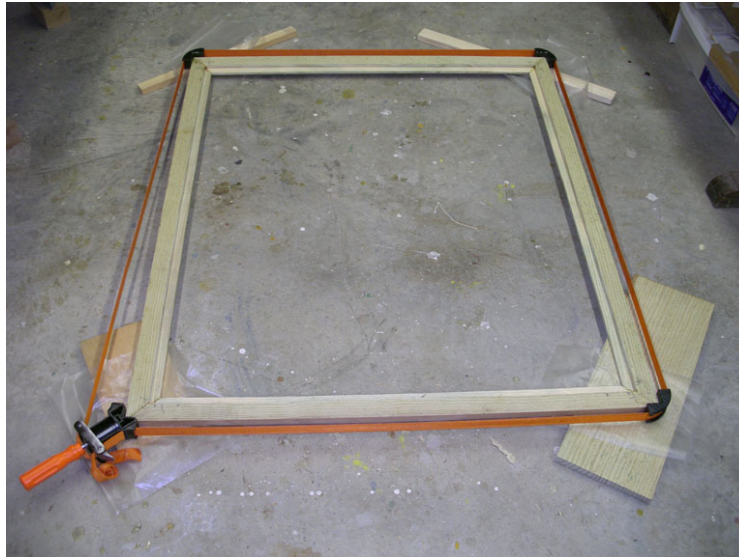

Photo 2-8: Mitered corners clamped with a web corner clamp

18. Screw the flat corner braces onto the back side of the mitered window frame corners. The edge of the braces must be 1" in from the outside edge of the frame so that the window will lie flat.
19. Take the glued frame to the County Store to have the Plexiglass panel cut.
20. Use the strips saved from step # 15 to fasten the Plexiglass in place. Drill holes thru the long side of these strips, then nail in place with stainless steel brads.
21. Set the windows in-place and again check for fit. It may be necessary to plane the edges of the frame members to avoid binding.
22. Apply silicone caulk to front side of the window frame. Allow to set for at least one day before proceeding with the next step.
23. Screw the hinges to the top of the frame and the hasp and two barrel bolts to the bottom of the frame. The barrel bolts should be about 4" in from the edge
24. Apply silicone caulk to all gaps on the front and on the back.

Mounting the Finished Kiosk



Photo 2-9

This is the Kiosk at the Shady Lane Entrance to the Mayflower Preserve. Any dead trees that could fall onto the kiosk should be taken down before the kiosk is installed. It is helpful to drive two grading stakes into the ground at the center points of each leg; i.e., about 50" - 52" apart.

Holes three feet deep should be dug with a post-hole digger to keep the diameter of the holes narrow.

About four people will be needed to mount the kiosk. The kiosk should be stood up-right with the legs to one side or the other of the holes. **DO NOT** start with the legs in the holes - if this is done, dirt will fall into the holes and the final position of the kiosk will be too high.

Once the kiosk is vertical, lift and move it until the legs are over the holes, then gradually lower it into the holes.

First, the kiosk should be leveled in the horizontal direction by throwing small amounts of dirt into the lower hole and raising that leg slightly to allow dirt to get under that leg.

When the kiosk is level horizontally, dirt and stones can be put into the holes in increments and tamped thoroughly after each increment is added. During this time, the vertical level can be adjusted.



Figure 3-1

3- Small Kiosk

Small kiosks are used for displaying a limited number of the most useful documents and are often placed at secondary trail heads. Figure 3-1 is a photo of a small kiosk on the Patch Hill Trail.

It is most efficient to make 6 small kiosks at one time. The list of materials required is:

- (1) sheet of 3/4" AC exterior plywood cut into 6 equal 24" x 32" pieces. (P.J. Currier will cut to size)
- (3) pieces pressure treated 2"x4" x 12'
- (2) pieces 1"x8" x 12' pressure treated boards
- (6) pieces 4"x4" x 10' pressure treated posts
- Stainless steel ring siding nails: 5D 1-3/4" and 8D 2-1/2"
- (12) 3/8" x 5" galvanized carriage bolts, nuts, and washers
- Clear silicone caulk, exterior
- Glue: Tite Bond III is recommended. Apply with a disposable solder flux brush.
- Cabot Clear Solution, Natural, No. 9200.

A table saw and drill are required power tools. A featherboard should be used for most of the cuts with the table saw. Other useful power tools include a radial arm saw and a drill press.

Construction Details

1. Cut two 24" pieces from one of the 8" boards. On the table saw fitted with a narrow kerf blade, rip six 3/4" strips (to be nailed to the bottom of each plywood piece, and six 1" strips. Tilt the blade to 15 deg then re-cut the 1" pieces to give a 15 deg bevel on one edge. These pieces will be nailed to the top of each panel.
2. Glue a 3/4" strip to the bottom of each panel.
 - a. Cut the strip to the exact width of the panel.
 - b. Drill (4) 3/32" pilot holes - apply glue to all mating surfaces - nail in place with the specified 5D nails. [It is helpful to clamp a strip of scrap wood to the back of the panel. It should stick above the edge of the panel to serve as a gluing jig.]
3. In a similar way, cut, glue, and nail the 1" beveled strip to the top edge of each panel. Be certain that the flat edge is the glued surface and that the slope is from back to front.
4. Drill two 3/8" holes in the plywood for the carriage bolts using a brad-point wood bit. These should be 4" in from the edge of the plywood. [It is helpful to make a nailing jig so that all holes can be marked so that they will be equally spaced, both on the Kiosks and on the posts.] Make a nail prick on the back side of the panel to locate each hole. Drill 5/64" holes thru the plywood to mark the locations on each side. Partially drill the 3/8" hole on the back side. Turn the panel over and finish drilling the 3/8" holes.

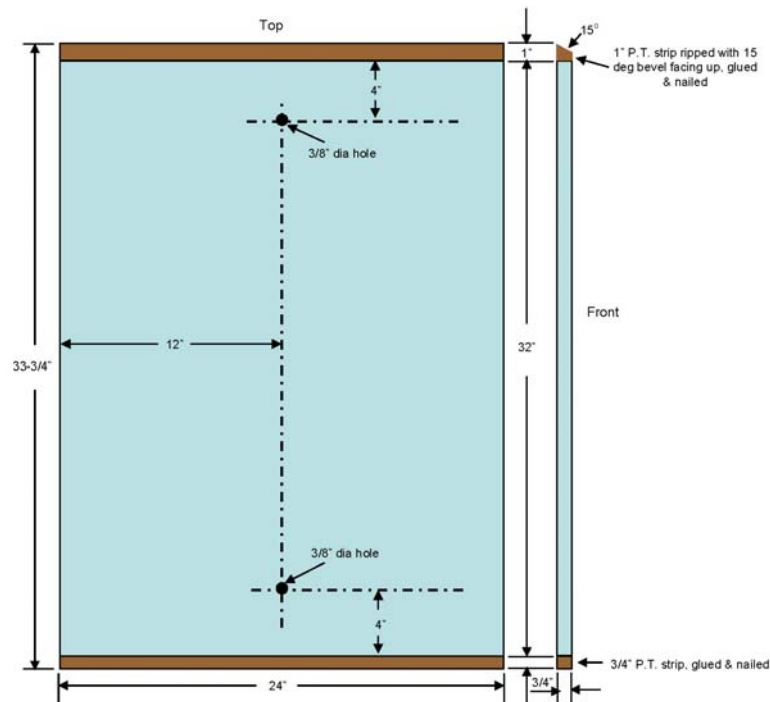

Figure 3-2

5. Cut 12 side pieces from the 2"x4"s using a radial arm saw if available.
6. Cut out a 3/4" x 3/4" groove on the back side of each piece. The panel will be glued into this groove. Use a narrow kerf blade on the table saw. These must be cut in mirror-image pairs.
7. Glue and nail the 2"x4" side pieces to each panel.
 - a. First, cut each pair to the exact size of the panel to which they will be attached.
 - b. Drill 5 pilot holes for the nails.
 - c. Place the side pieces on the panel and mark the plywood to show where glue will be applied.
 - d. Apply glue to all mating surfaces on one side and nail in place.
 - e. Do the same for the opposite side.

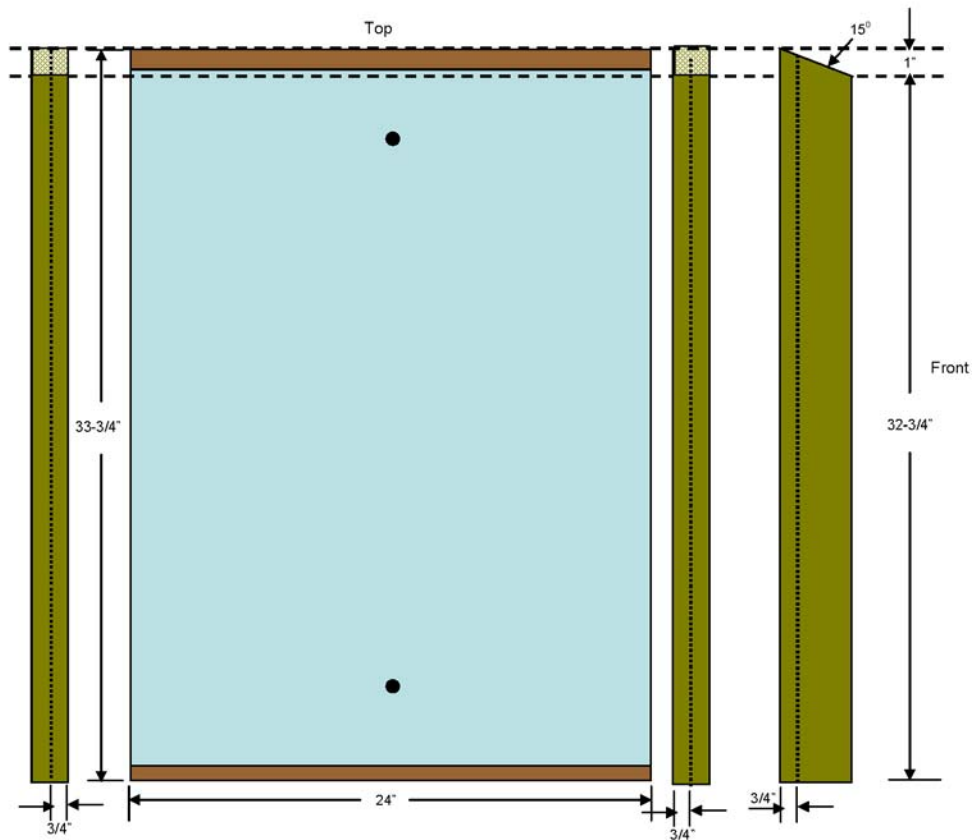



Figure 3-3

8. Cut the remaining 8" boards to the length required for the roofs. For a 2" overhang on each end, the length of each board should be 29-1/2". Check the growth rings on the end grain.  Make sure the growth rings form a "frown" (rather than a "smile") - this will minimize "cupping" of the roof board over time.
 - a. Tilt the blade on the table saw to 15 deg, then rip all roof pieces to give a 15 deg bevel on one (the rear) edge.
 - b. On the under side of what will be the front edge of each board, cut a groove (the width of the saw blade) 1/4" deep 1/2" in from the edge. (This groove helps to prevent rain flowing onto the panel surface.)

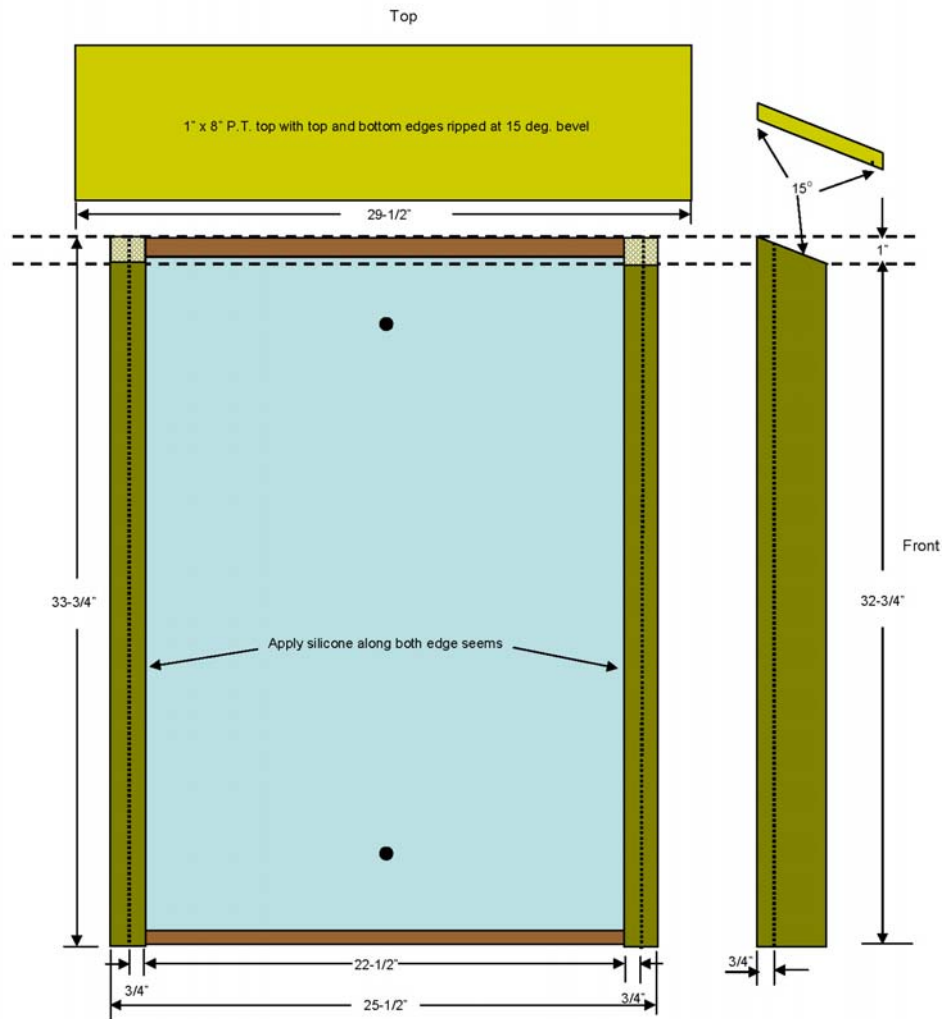

Figure 3-4

9. Nail the back edge of each roof board to the plywood panel with the 5D nails. At each end, nail the roof panel into the 2" x 4" side pieces with the 8 D nails. Do not apply glue since the roof is the piece most likely to break and need future replacement.
10. Caulk all cracks and holes on the back side. Turn the unit over and apply caulk along both sides where the plywood joins the 2"x4s".
11. When the caulk has cured, apply one coat of Cabot sealer to the front and back of the plywood.
12. Using a radial arm saw (or a Skil saw) with the blade tipped to about 25 degrees, cut all four sides of one end of each of the 4"x4" x 10' posts.
13. Make a mark approximately 10" down from the edge of the bevel cut, directly in the center of each post. From this mark, measure down another 24" and make a second mark, again directly in the center of each post. [If you made a jig as suggested in step 4, above, you should use that here to mark each post for drilling.] Center a kiosk on each post, and using a nail, double check to see that the marks on the post line up exactly to the holes already drilled in the kiosk base. Once aligned properly, drill the holes in each post using a 3/8 "diameter drill bit.
14. Using the 3/8" x 5" bolt, attach a kiosk base firmly to each post, using a washer on both

the inside and outside. Check that the base is square to the post before tightening the nuts.

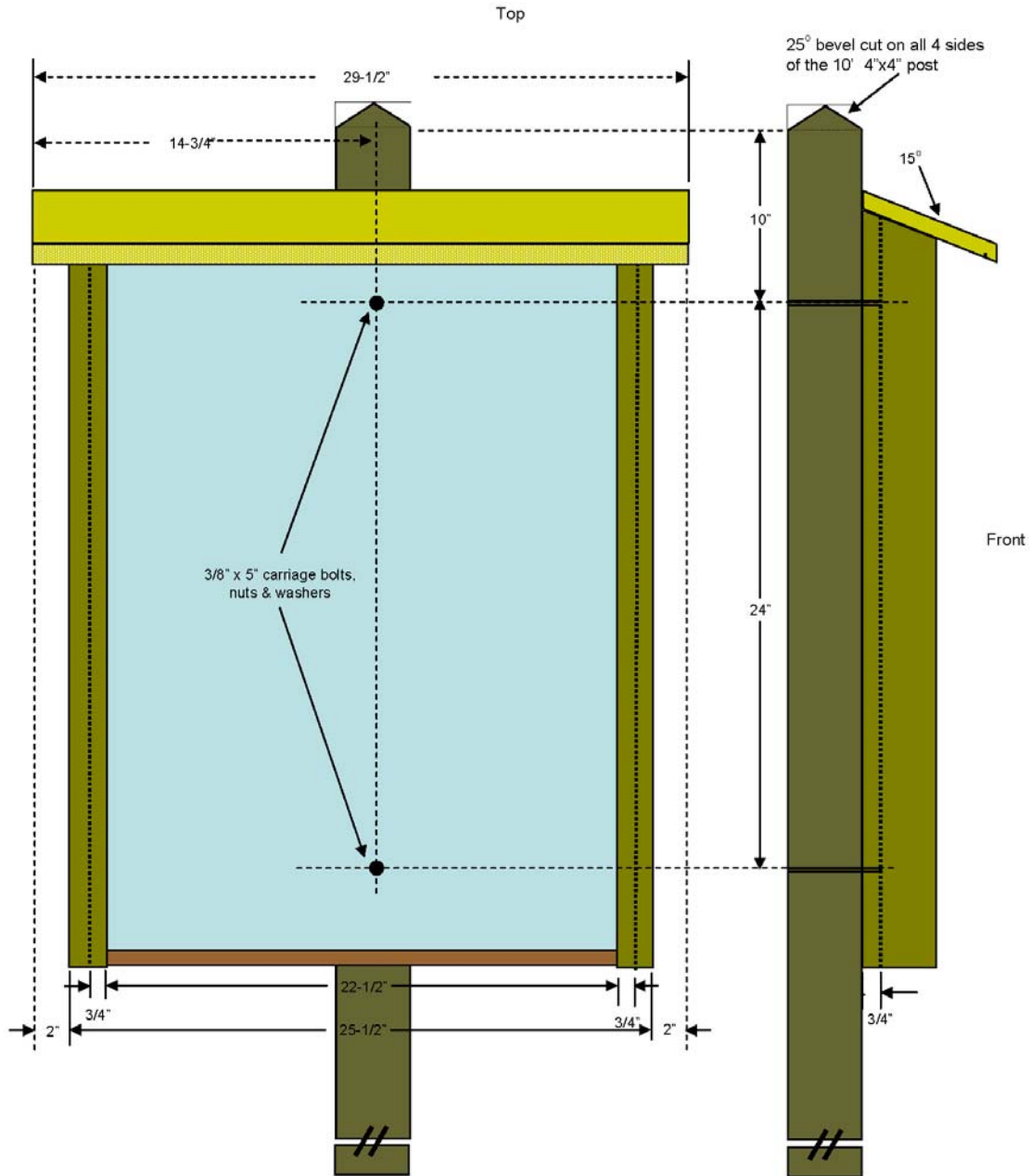

Figure 3-5

Mounting the Finished Kiosk

Any dead trees that could fall onto the kiosk should be taken down before the kiosk is installed. A hole three feet deep should be dug with a post-hole digger to keep the diameter of the hole narrow. Two people will be needed to mount the kiosk. The kiosk should be stood up-right with the leg to one side or the other of the hole. **DO NOT** start with the leg in the hole - if this is done, dirt will fall into the hole and the final position of the kiosk will be too high. Once the kiosk is vertical, lift and move it until the leg is over the hole, then gradually lower it into the hole. With one individual watch the post for plumb with a level, dirt and stones can be put into the hole in increments and tamped thoroughly after each increment is added.

4- Information Boards

Information Boards are used in the White Mountain National Forest. Photo 4-1 is a picture of a back-to-back pair seen in the Zealand Notch area. Photo 4-2 is a picture of the CLMC version mounted on a tree in Tucker Brook. The CLMC uses such Boards along town trails to display maps or other useful information. They will accommodate one 8½" x 11" sheet oriented either vertically or horizontally. These documents are laminated and attached with ¼" Monel staples.



Photo 4-1



Photo 4-2

Figure 4-A is a measured drawing of the finished Information Board. (This figure shows the Information Board mounted on a post. Usually these Boards are mounted on trees and therefore would not need posts.)

Figure 4-A

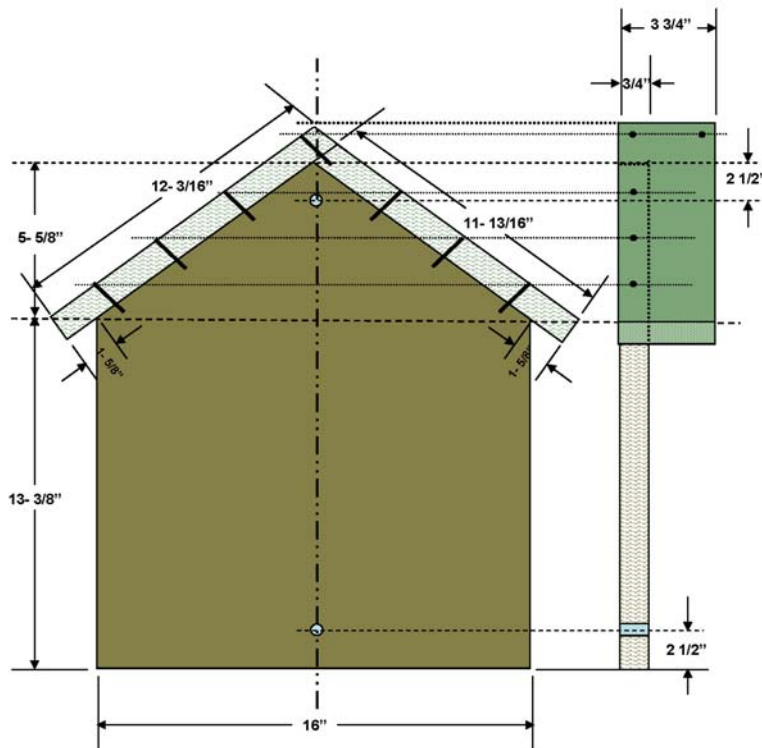

The most efficient use of materials and construction time is to make 15 Information Boards at one time. The list of materials required is:

- (1) Sheet of 3/4" AC exterior plywood cut into 3 equal 16" x 8' pieces. One sheet will produce 15 Boards. (P.J. Currier will cut to size)
- (2) Pieces 1"x8" x 12' pressure treated boards for roofs.
- Stainless steel ring siding nails size 5D 1-3/4"
- Ceramic coated decking screws: 6 x 1 1/2" with #2 square driver
- (15) 5/16" x 3" galvanized lag bolts and washers
- Cabot Clear Solution, Natural, No. 9200.

The power tools that are most useful are a table saw equipped with a narrow kerf blade, a radial arm saw equipped with a plywood cutting blade, and a drill press.

Construction Details

A. Cutting the plywood pieces for each Board

1. Cut the three 16" wide lengths of plywood into 19" lengths. This will give fifteen 16" x 19" pieces.

Figure 4-B

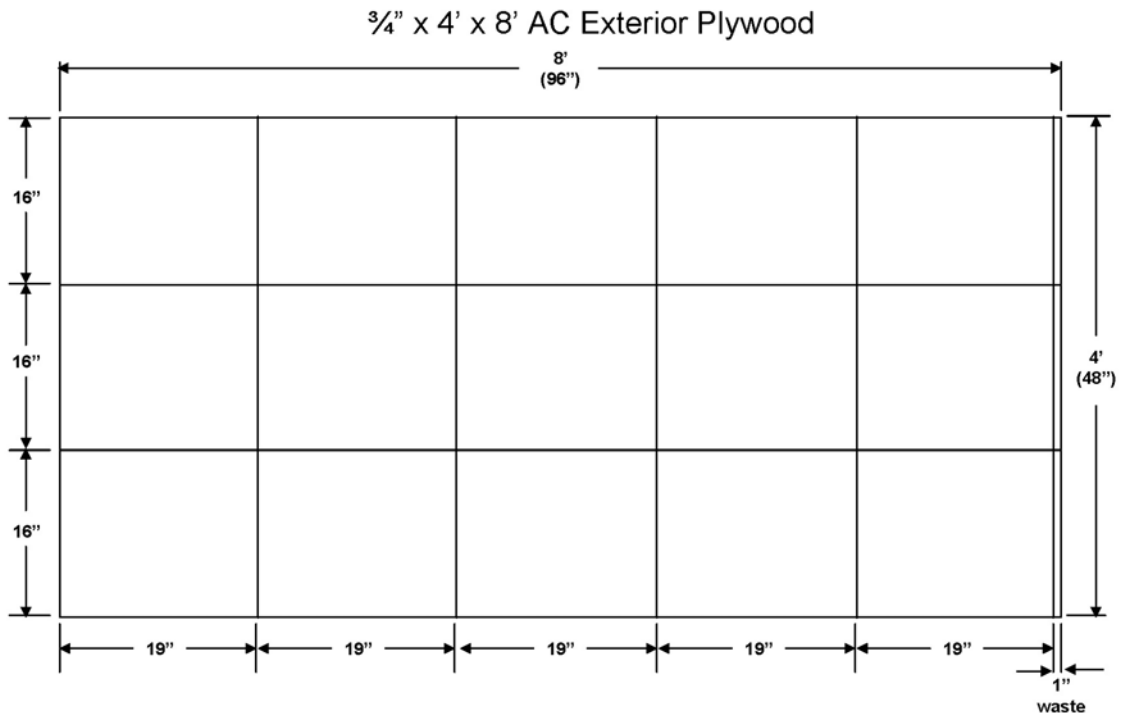

2. On each piece, draw a vertical center line. On the back side, mark this center line just at the top of the board (where the cut on the back side will start).
3. On one of these pieces - with a protractor, mark a roof line at a 35 deg angle (or the 55 deg complementary angle) and draw this line from the center line to one side. Alternatively, make a mark at 5-5/8" from both the top right and top left corners of the sheet. Draw a line connecting the top center to each side mark. This creates the 35 degree slope on each side of the center line.

Figure 4-C

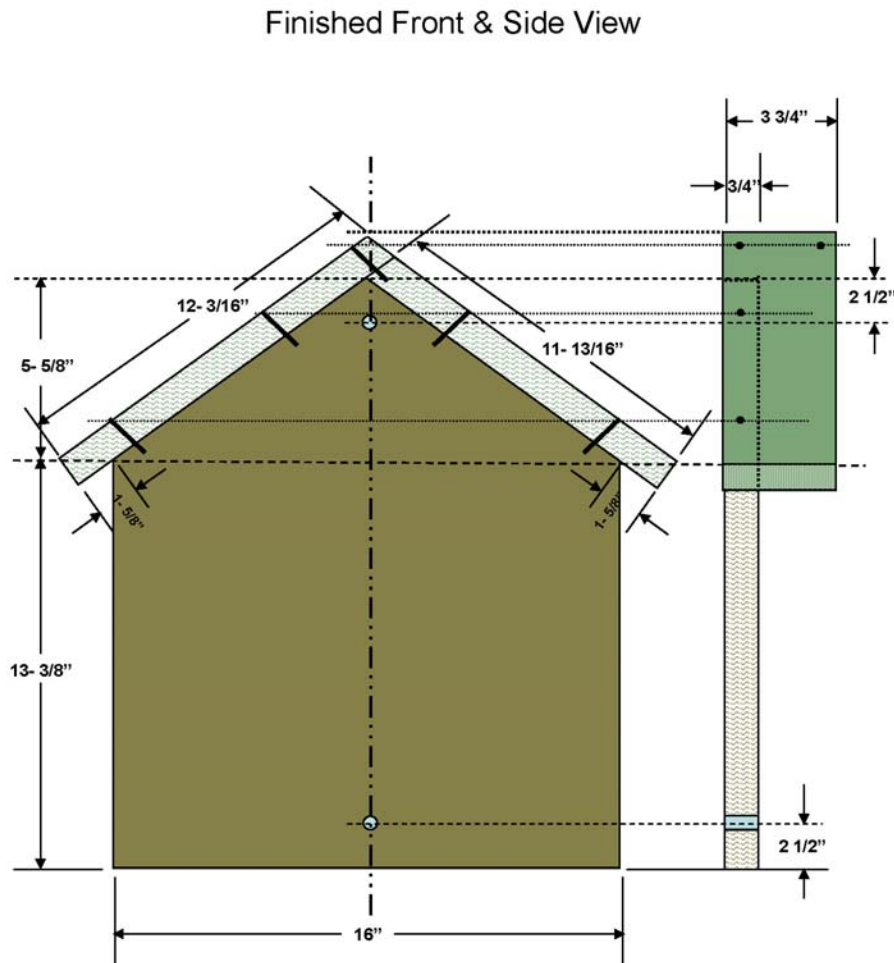

4. Raise the blade on the radial arm saw to give just a bit more than 3/4" clearance, then move the arm to the 45 deg position.
5. Adjust the position of the piece so that the saw blade travels exactly on the marked roof line while one corner of the piece of plywood is against the fence.

6. Screw a scrap piece of lumber onto the table flush against the edge of the plywood. This picture illustrates this. (In this picture, only a clamp was used. The better technique is to fasten it down with 2 decking screws.)



Photo 4-3

7. Drop the saw down, then cut one roof line, starting exactly at the center line. Use a hand saw to complete the cut, if necessary.
8. Flip the board over and repeat the cut on the opposite side; again, starting exactly at the center line.
9. Drill holes for the mounting lag bolts. Mark points on the centerline that are 2-1/2" in from each end (see Figure 4-A). Drill holes at these marks with a 5/16" brad-point wood bit.
10. Optional: The life of the plywood face plate can be extended by gluing a 3/4" pressure treat strip to the bottom of the plate. The 3/4" plywood may not be exactly 3/4". If it is not, cut the plywood strips to exactly this width. Cut the strips to length and drill 3 pilot holes in each for nailing. Glue and nail the strips to the bottom of the plate. Stainless steel ring siding nails size 5D 1-3/4" are recommended

B. Cutting the roof boards

1. Using the radial arm saw, cut the 8" boards into pieces that are exactly 24" long.
2. To cut the correct angle in the roof boards, take one of the plywood backs, once it has been cut as described above, to the table saw; bring the blade of the saw all the way up; place the back with the left roof slope flat on the table perpendicular to the right side of your blade; tilt the blade until it is exactly flush with the right roof slope.

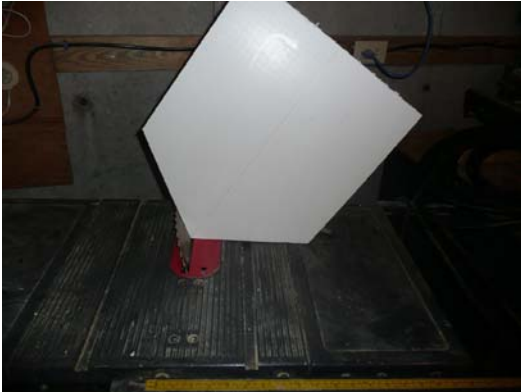

Photo 4-4

With the proper angle set on your table saw blade, cut the board per the dimensions indicated in Figure 4-D.



Photo 4-5

This will give two roof pieces of two different lengths which will be exactly the dimensions needed to provide for the overlap when these pieces are nailed to the plywood face piece.

Figure 4-D

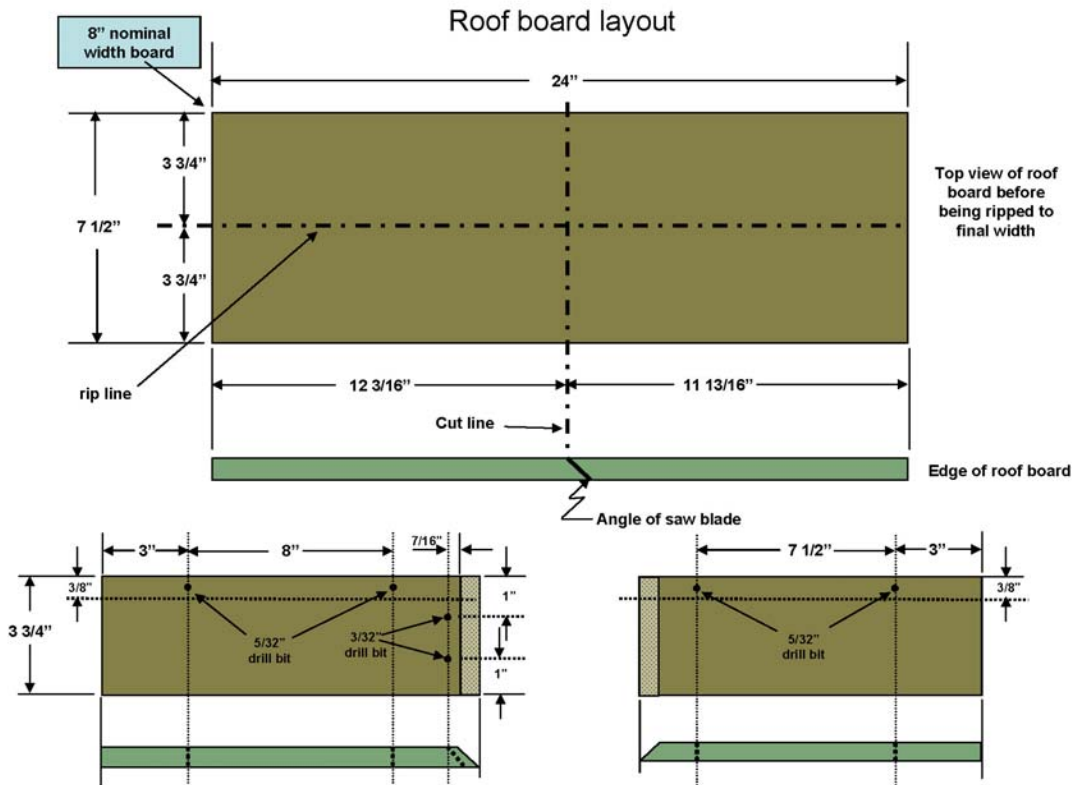

3. Using the table saw, rip each piece exactly in half to give two pieces about 3-3/4" wide. (It is helpful to run each piece through the saw again so that any differences in width are eliminated.)
4. Stack the shorter pieces in one pile and the longer pieces in a second pile.

B. Drilling holes at the edges of the roof boards for the decking screws

Note: Each roof piece is attached to the plywood with two decking screws. Previously, these pieces were attached by nails - vandals ripped some of them off. Attachment by decking screws should eliminate this problem. The two roof boards are nailed together at the peak.

Arrange each pile of roof pieces so that they are all in exactly the same orientation; i.e., the beveled ends are all in the same alignment. Use this orientation during drilling holes for the screws. This is very important!

1. Figure 4-D shows the location of the drill holes. On the shorter boards, mark the location of these points. With a hammer and nail, make a punch mark at each of these. Drill the pilot holes with a 5/32" bit.
2. Take one plywood face board, one of the drilled short roof boards, and one of the un-

- drilled longer boards. Orient the two roof boards so that they overlap correctly (see Fig. 4-A) and mark the edge where the screws will go. (Note: It is very easy to drill the holes on the wrong edge.)
3. Mark the location of the 2 pilot holes (see step 1) on these longer pieces. After just one is drilled, check again for the correct orientation to be certain that the holes are being drilled on the correct edge.

D. Drilling angled holes at the roof juncture

Two holes are drilled at the beveled edges of the longer roof boards since these are the ones that overlap the shorter boards.

1. Set the table of the drill press to 22 deg (left side low, right side high). [This applies to a Delta drill press. Other models may have a different scale.]
2. On the long side of the beveled edge, draw a line $\frac{3}{8}$ " in from the edge. With a nail, make a punch mark where each nail will go.
3. Drill out these two holes on each long piece using a $\frac{3}{32}$ " bit. Again, after the first piece is drilled, check that the angle and orientation are correct before proceeding.

Note: It is very helpful to save one pair of correctly drilled roof boards as a model for future use. Mark them with a magic marker to identify them.

E. Attaching the roof pieces to the plywood face boards

1. Clamp a plywood face board to the radial arm saw table and orient a pair of roof boards in-place.
2. Screw the shorter roof board to the faceboard after it is brought flush with the longer board.
3. Orient the longer roof board so that the rear beveled edge is exactly flush with the board already screwed in place, then screw in the 2 side screws.
4. The two roof boards may not exactly match up. If this happens, loosen the screws on the board that protrudes, align the boards until they meet correctly, then drive in the 2 nails. Finally, re-tighten the loosened screws.

- F. Sealing: All surfaces should be given one coat of Cabot Clear Solution, Natural, No. 9200, outdoors. It is beneficial to treat them again at about 1 year intervals.

5- Routed Signs and Posts

A. Construction of Small Routed Wood Signs

The Milford Conservation Commission has acquired a large stock of used redwood tongue-and-grooved planks. These have been trimmed, split, and planed to give pieces that are 3/4" x 4³/₈" x about 48". This stock is to be used for all routed signs on Milford town forests and trails. These are suitable for signs with a single row of lettering. Sometimes a double row is needed. This is best done by ripping the 4³/₈" stock in half to produce two pieces about 2¹/₈" wide. These can be glued edge-on to pieces of the original stock to make wider signs. This is best done using a biscuit cutter. Titebond III waterproof glue is recommended. [Note that these wider signs will require wider backing plates than described in § B below.]

The maximum length of the signs should be about 20". If the lettering would require a longer sign, it is best to use the wider stock described above and use 2 rows of lettering. Metal routing stencils are available in font sizes 1¹/₂" and 2¹/₂". The 1¹/₂" size should be used for most trail signs.

The sign should be sealed with Cabot 9200 Clear Sealer either before or after routing. If sealed after routing, the sealer should be applied with a low-nap roller to prevent the sealer from getting into the lettering. (Foam rollers have proven unsatisfactory for this use.) This sealer prevents the lettering paint from penetrating into the non-routed surface. The sealed boards should cure for several days before the lettering is painted.

The letters should be painted with one coat of oil-based primer followed by two or three coats of the same yellow oil-based paint specified for blazes. (It is helpful to have yellow pigment added to the primer at the time of purchase.) After fully drying, the excess paint can be removed with a sander. The final sign should receive another coat of Cabot 9200 Clear Sealer

B. Mounting the Small Routed Wood Signs

The method described here for mounting these signs is a slight modification of the method developed by Don Ray, *Friends of the Wapack*, for signs used on the *Wapack Trail*.

The routed sign is mounted on a back plate made of 6" wide pressure-treated 5/4 (actual 1") spruce pressure-treated decking cut to a length appropriate for the specific sign. The sign is drilled with 4 or 6 small holes for later attachment of the sign to the back plate with ceramic coated decking screws, #2 square driver, 6 x 1¹/₂".

Four holes are pre-drilled in the back plate for attachment to a tree with 5/16" lag screws and washers. They are spaced to allow for either horizontal or vertical mounting. These holes must first be counter-bored into the back plate to provide a flush surface for mounting the redwood sign. The diameters of these counter-bored holes must be slightly larger than the diameter of the washers (1-0" is a good choice). This can be done with a

Forstner bit or a spade bit. Then, drill the two smaller holes through the board with a 5/16" bit.

Figure 5-1: Back-plate for small routed wood signs

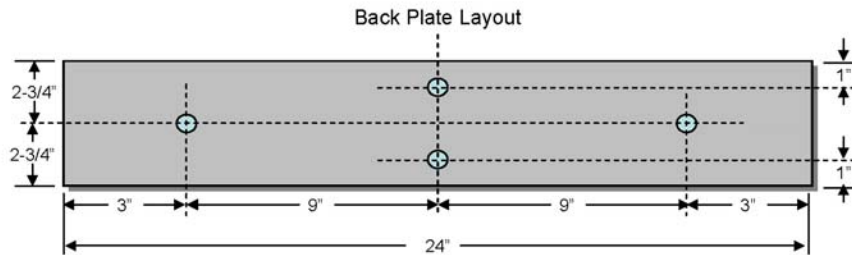

Note: Figure 5-1 is for a sign that is 24" long. This is just an example. The length will vary depending upon the actually lettering for a specific sign.

When the sign / back plate are ready to mount on a tree, first attach the back plate to the tree with the two lags. Apply a bead of silicone caulk to the upper inner edge of the sign and then attach the sign to the back plate with the decking screws.

In areas where vandalism is expected, the signs can be mounted vertically. The orientation should be such that the lettering reads from bottom to top.

Due to tree growth, every few years, the signs will have to be taken down and re-mounted. This would be a good time to re-paint the lettering and stain the wood.

C. Construction and Mounting of Town Forest Signs

Photo 5-1 is a picture of a Town Forest sign.

The dimensions of these signs is about 18" x 36" - 40". These are made by first gluing four redwood boards previously cut to the correct length. Boards should be selected so that only flat edges are glued. (Half the boards have a bevel at one edge – these can be used for the outer two boards.)

After the boards are selected and laid out, they should be numbered using *Post-It Notes*, starting with #1 for the back board to #4 for the front board. They are then inverted and 5 marks are made on the all edges to mark where the center of the cuts with the Biscuit Cutter will be made. The depth of the cut should be adjusted for a size "0" biscuit.

After the slots are cut, the boards are returned to right-side-up. The biscuits should be glued into the forward-facing slots. Titebond III glue is recommended since un-cured glue can be easily wiped off with a wet sponge. It is best to spread the glue with a disposable stiff flux soldering brush. The surface where the gluing is to be done should be covered with light duty plastic sheeting. (Large black trash bags split to a single sheet work well.)

Narrow boards 18" wide and covered with plastic or wax paper should be prepared from scrap wood. These are needed to hold down the edges to prevent buckling when gluing and clamping.

Photo 5-2 is a picture of a set of boards being clamped on the table of a radial-arm saw.

Gluing is least cumbersome if done in this order:

1. Apply glue to the edge of #4 and the mating edge of #3, then push the two together.
2. Do the same for #1 and the mating edge of #2.
3. Apply glue to the other edges of # 3 and # 2 and push all 4 boards together.
4. Apply light pressure with 2 clamps and squeeze the joints together.
5. Remove the clamps and wipe off the excess glue.
6. Invert the joined boards end-for-end. Remove the plastic sheet and replace it with a clean sheet before laying the boards down. Clean off the excess glue on the back side.
7. Invert the boards again so that the good side is up.
8. Lay a strip of wood along the exposed edges of #1 & #4 to protect the boards from denting by the clamps.
9. Clamp lightly with 4 pipe clamps.
10. Wipe off the excess glue again, then clamp down the two edges with C clamps using the short boards previously prepared.
11. Further tighten the 4 pipe clamps.

The glued boards need to be strengthened by gluing 4 strips of pressure-treated boards on the back with 1½" decking screws. These boards should be about 2" shorter than the width of the sign. The outer strips should be glued about 1½" in from the edge. The drill holes needed for these screws is 5/32". After the glue has cured, these screws must be removed so that they will not cut into the sandpaper during sanding nor damage the router bit during the later lettering operation.

The corners are then rounded. Mark the cutting lines on the front side with a compass set to a 2" radius. Cut the 4 corners to the marked lines with a sabre saw.

The edges should be sanded and the front edges of the boards should be rounded by sanding with 80 grit sandpaper. The surface of the facing boards should be sanded just enough to remove glue or pencil marks. An random orbital sander is recommended for sanding the flat surface.

The boards are now ready for routing the lettering by a company that has a computer-controlled routing machine. One such company is Classic Signs, 13 Columbia Drive, Amherst, NH.

The routed sign then needs to be finished in the same way as described in § 5-A above.

The holes on the back side where the screws were removed should be filled with silicone

caulk; or, the screws can be replaced with 1 ¼" cement coated decking screws.

The signs should be mounted on a single 4" x 4" x 10' pressure treated post with two ¾" galvanized carriage bolts / nuts / washers.



Photo 5-1



Photo 5-2

6- Cultivated Land – Trail Boundary Posts

These posts must be made from pressure-treated lumber. They can be 4 x 4s or 2 x 4s. These markers must usually be quite tall so that the farmer can see them when the field is planted to tall crop. Typically, 8 ft 2 x 4s are adequate.

It is recommended that two cuts of 30 - 35 deg each be made at the top of each 2 x 4 (or 4 cuts with a 4 x 4) post to produce a triangular edge which will better shed water or snow. The top section must be painted on all 4 sides with at least 2 coats of the appropriate color of the same paint used for blazes. The length of the painted section should be 6 - 8".

Installation of these posts must be with the approval of the landowner. Preferably, the posts should be installed at the minimum distance into the tilled area that can provide the standard 4' trail width; however, that may not be allowed by the landowner. It is preferable to cut brush than to impinge upon the field.

7- Bridges

Construction of Small Bridges

The bridges described in this section are designed for use by hikers and by mountain bicycles. Such bridges are not suitable for snowmobiles since they require a 40" width and much sturdier construction.

Several volunteers constructed two bridges over small streams in the Tucker Book Town Forest. This section documents the specifications used and how these bridges were constructed.

Photos 6-1 and 6-2 are photos of the completed bridges. Bridge 1 required a curve to provide proper access and was broken into two major sections in the middle by a large rock. Bridge 2 was a more typical straight bridge.



Photo 7-1: Bridge No. 1

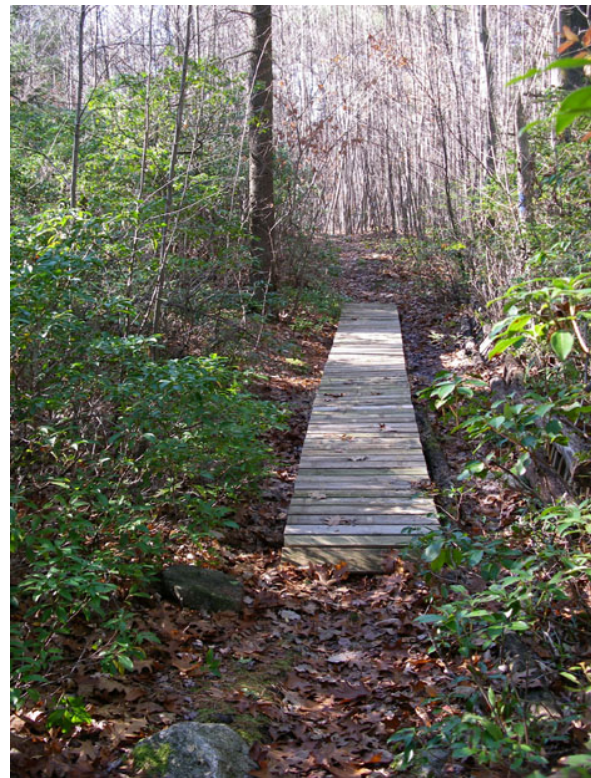

Photo 7-2: Bridge No. 2

Tucker Brook Bridges - November 2005

Photo 6-3 shows an example of how to “fan” the decking plates, and the use of varied sized decking plates, to form a smooth curve around an angle, as had to be done in the construction of Bridge No. 1.



Photo 7-3

Specifications:

Lumber: all Pressure-treated; planks used were 5/4" x 6" decking (1" thick, 5 1/2" actual width); joists used were 2" x 6". Long unsupported spans may require a center (third) joist. Bog bridges may require 2"x 8"s or even 2" x 10"s.

Width: 32" (2'-8") (If these are cut from 16' boards, there will be no waste.)

Spacing between planks: 1/2" recommended, 3/4" maximum.

Screws and Nails: Use 2" or 2 1/2" cement coated decking screws for the first plank at the end of each individual section. (This allows adjustments which may be needed when the joists are mounted in place.) Also, use these screws to attach the decking planks to the tapered ends of the joists and to join joists at abutting sections (see Figures 6-3 and 6-4). Attach the remaining decking boards to the joists with 8d galvanized spiral nails. (Decking screws can be used for the entire bridge instead of nails.)

Supports: Every joint where two joists butt together must be supported by stones.

Power Saws: Salvaged pressure treated lumber is generally used when available. Such material may have hidden nails. A nail-cutting blade must be used when cutting such stock. [If a standard blade is used a tooth could break off and cause serious injury.]

Tools Needed at the Construction Site:

Each volunteer should have a tool belt and hammer. Other tools needed include:

Battery-powered driver plus spare fully charged battery - for the decking screws

Measuring tape

Saw - to cut roots or to shorten joists

Mattox or Pulaski tool- to level the area or to dig out places where stones are needed to support the bridge joists

Crow bar or pick axe - to pry out stones needed for construction.

Loppers, if needed

Description of Accompanying Figures:

Figure 6-1: General design details

Figure 6-2: Details of the tapered ends of each bridge [cutting of the 2" x 6" joists and attaching decking at the construction site]

Figure 6-3: Details of Construction that Requires Joining of Two Sections at an Angle [e.g., Bridge No. 1]

Figure 6-4: Pre-Construction Diagram of the Layout of Joists for Bridge No. 2

Suggestions for Project Planning and Execution:

1. Before any work is done, the two people assigned to manage the project should examine the site and record the lengths of the spans that will be needed, decide how materials could be transported to the site, and assess any other pertinent details that will affect construction; e.g., the approaches from each end for easy access by both hikers and bicycles must be evaluated.
2. A diagram, drawn to scale, of the lay-out of the paired joists, needs to be drawn. From this, the materials list can be developed. [Fig. 6-6 is an example of the plan for Bridge No. 2.]
3. All lumber should then be acquired, pre-cut, and the joists numbered so that it will later be clear where each piece goes once the materials are transported to the site (see Fig. 6-6).
4. Volunteers to help with the project need to be found. Our experience is that as many as possible will be helpful to transport materials to the site but that 3 (4 maximum) is the ideal number for actual construction.

Comments / Observations:

- When the bridge components are cut, it is helpful to attach the two ramp pieces at each end before the material is moved to the final site. If one of the joists is warped, it can be forced into correct alignment with a clamp and then a plank can be temporarily screwed at the center of the joists to hold this alignment. This pre-assembly may not be practical if the section needs to be carried a long distance through the woods.
- The strength of the bridge can be increased by adding a third stringer in the center. This is advisable if the bridge is to span a gully or is to cross a stream and will be above the water by more than one foot.
- Used material may be brittle. Pre-drilling holes in the planks may be useful. Planks made from old material should be nailed with the weathered side down.
- An ATV can be very useful for transporting materials to the site.
- The longest practical length for the joists is about 12'. Anything longer may be too heavy or too awkward to transport through the woods.
- Joists will often need to be butted and joined. The 32" decking planks can be used for this purpose. They should be attached using decking screws. Joining the two joists with a single plank on the outside is adequate for 2" x 6"s. Use of two planks (one on the inside, the other on the outside), can be used for greater strength. (See Figure 6-6)
- Sometimes, sections of a bridge will need to be attached at an angle to obtain suitable access at one end. This was the case with Bridge No. 1 (see Fig. 6-5). In this case, one joist will

need to be shortened to obtain the correct angle. Metal straps will need to be bent and attached at such joints. The side braces will still be needed even though they will not lie flat against the joists (see Fig. 6-5).

- It is helpful to bring along several pieces the exact width of the gap between planks and longer than 32". These can be used when nailing the planks to keep a uniform gap.
- It is also helpful to rip a few pieces of 32" decking to different widths to use when pieces less than the full width are needed. Obviously, these will need to be cut off-site at the same time that the lumber is being pre-cut.

Figure 7-1: Construction Details

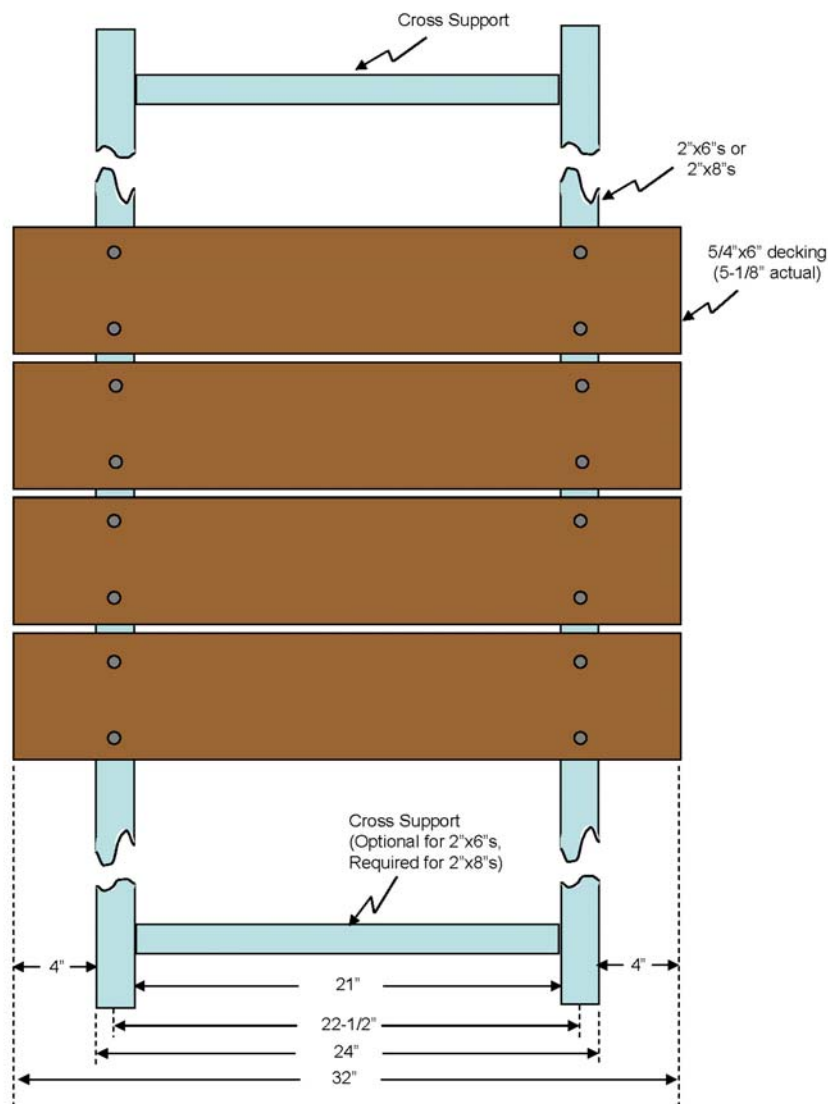

Figure 7-2: Details of Cutting Joists and Construction of Tapered Ends of a Bridge
[This avoids tripping-hazards and allows access for bicycles.]

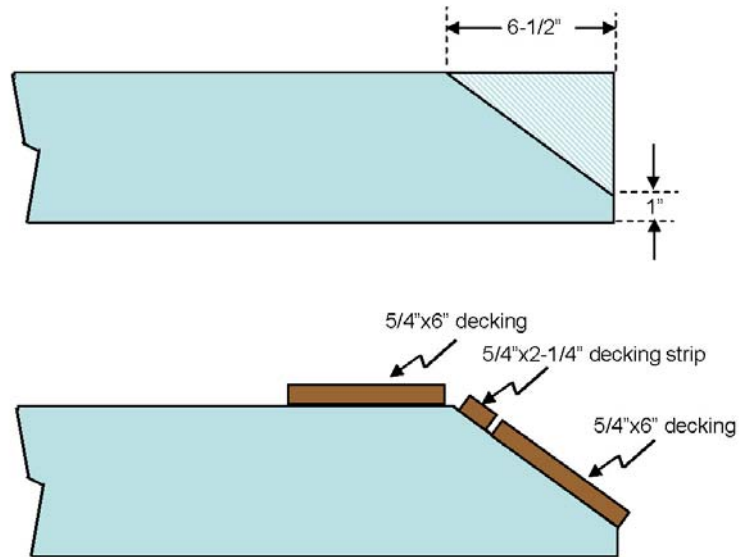

Figure 7-3: Details of Construction that Requires Joining of Two Sections at an Angle

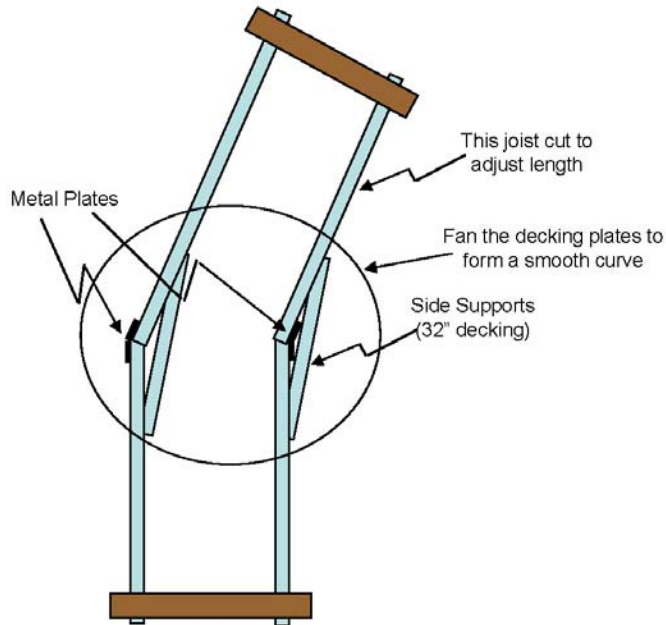
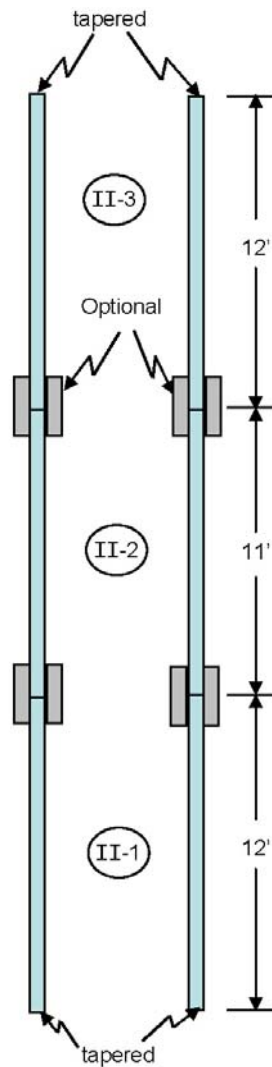

Figure 7-4: Pre-Construction Diagram of the Layout of Joists for Bridge No. 2



Note: Each joist was numbered (using a Magic Marker) with the circled numbers for identification at the construction site.

8- Backing Plates for Metal Directional and Boundary Signs

Metal Directional and Boundary signs are the same size; $5\frac{5}{8}$ " x $5\frac{5}{8}$ ", and 8" across the diagonal. There are situations where these signs need to be mounted on a backing plate which is in-turn attached to a wood or metal post. The size of the backing plate is different for the two signs since the Directional signs can be any orientation and therefore can be mounted on a $6\frac{1}{2}$ " or larger square plate, but the Boundary Marker must be mounted vertically and therefore must be mounted on a larger 9" square plate.

We initially made these plates from pressure-treated lumber but this has often proven unsatisfactory since the lumber shrinks with time and the attached metal sign buckles. If such lumber is used it must be dried for several months before attaching the metal signs. We now recommend using exterior or pressure-treated plywood. One-half inch plywood is adequate for mounting on wooden posts. Thicker plywood is needed for mounting on metal posts if they are attached to the post with screws applied from the back-side.

This is a diagram of a backing plate for Directional Signs.

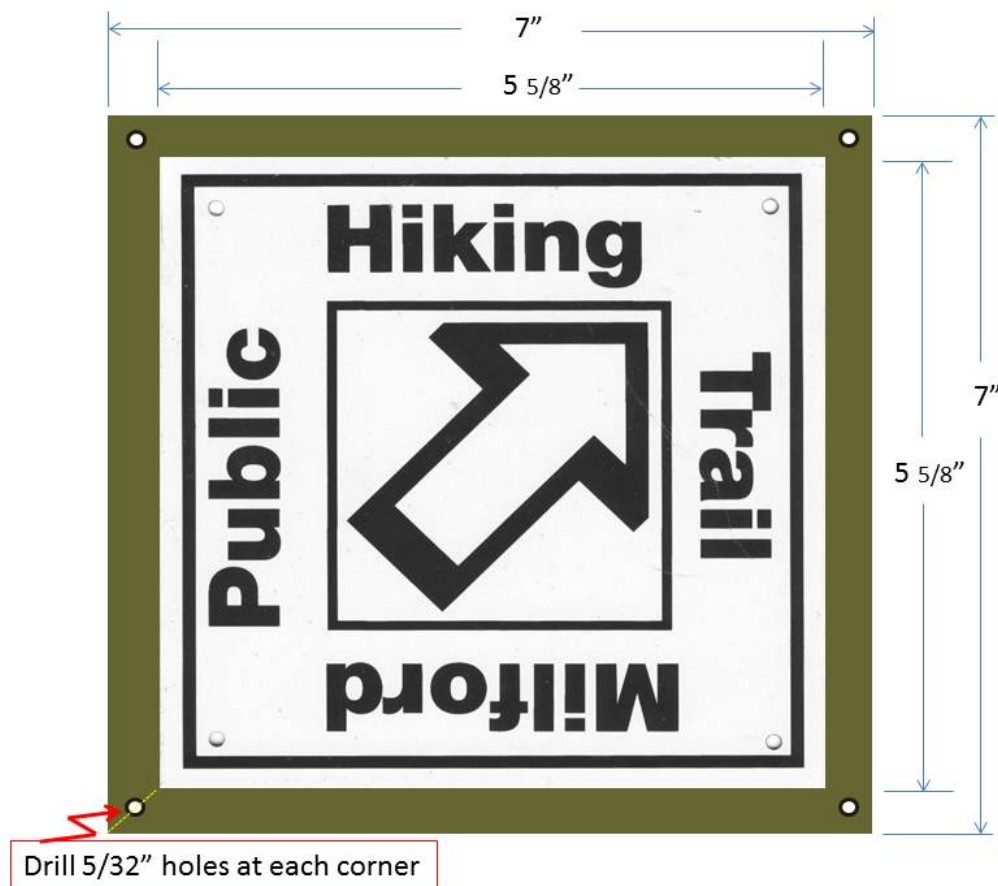

On the back of the finished plates, draw diagonal lines joining opposite corners. This will help in the vertical alignment of the plates.

Attach the metal signs to the backing plates with #6 x 1/2" pan-head (not flat head) stainless steel sheet metal screws. Do not use nails since they cannot be removed without wrecking the sign.

The order in which the screws are applied is important. Locate the metal sign on the backing plate, mark a pilot hole with a small nail, then screw this corner in-place. Next, do the same to the opposite corner. Finally, do this to each of the side corners.

If the plates are to be attached to small metal stakes, this can be accomplished with 1-1/2" decking screws. Alternatively, they can be attached by 2 flat-head bolts. If this method is used, the metal signs are screwed on after the backing plate is mounted on the stake.

Appendix E: Official MCC, Town of Milford, and State of NH Documents Pertaining to Trails

Milford Trail Maps

<http://www.conservation.milfordnh.info/AcrobatMaps.html>

Conservation Land Ordinance:

<http://www.conservation.milfordnh.info/Land%20Ordinance.html>

Camping Permit, with Release & Waiver of Liability and Indemnity Agreement

<http://www.conservation.milfordnh.info/business/Camping%20Permit.pdf>

State Law Regarding Posting of Signs

“635:4 Prescribed Manner of Posting. – A person may post his land to prohibit criminal trespass and physical activities by posting signs of durable material with any words describing the physical activity prohibited, such as ""No Hunting or Trespassing", printed with block letters no less than 2 inches in height, and with the name and address of the owner or lessee of such land. Such signs shall be posted not more than 100 yards apart on all sides and shall also be posted at gates, bars and commonly used entrances. This section shall not prevent any owner from adding to the language required by this section.”

Town Regulation Regarding Conduct on Conservation Lands

7.20.013: Conduct on Conservation Lands

F. Prohibited Conduct:

The following enumerated actions or conduct are prohibited on any Conservation Lands. Upon well founded information indicating that any person(s) committed any of the acts listed below, the Commission will report the same to the appropriate law enforcement officials for prosecution. The Commission will fully cooperate with law enforcement. This will include formally pursuing criminal prosecution for any illegal act(s) committed, or an arrangement for compensation, restoration and community service, as recommended by the Milford Police Department or appropriate law enforcement officials. **The Prohibited Conduct shall include, but not be limited to, the following:**

defacing, destroying or removing any sign, bench, fence, stone wall, or other structure(s);

defacing, destroying or removing any mineral, plant, animal or a part thereof, except as allowed in C and E above (hunting and fishing, academic research);

modifying the trails without permission in writing;
contaminating water;
littering, this includes paint ball and other activity that leaves materials on the property
when the activity is completed;
removal, filling, or other disturbances of soil surface, or any changes in topography,
surface or subsurface water systems, wetlands, or natural habitat.
the possession, consumption or use of controlled substances or alcoholic beverages.
offensive language.

The foregoing list is instructional only and not intended to be exhaustive and shall not be deemed to preclude the Commission, Law Enforcement Personnel or Town Officials from taking any other action available to them under applicable law as they deem necessary.